



SOLSTICE[®] **GAS BLOWING AGENT**

Conversion Manual

TABLE OF CONTENTS

INTRODUCTION	4
Solstice® Gas Blowing Agent (GBA) Overview	4
SOLSTICE GBA TECHNICAL DATA	5
Physical and Chemical Properties	5
Temperature Considerations	5
Solstice GBA Physical Properties – English Units	6
Solstice GBA Physical Properties – SI Units	7
Physical Properties – Continued	7
FLAMMABILITY CONSIDERATIONS	8
Flammability of Gases – Definitions and Measurement	8
Minimum Ignition Energy	8-9
Flammability Characteristics Summary	9
MATERIALS COMPATIBILITY	10
Compatibility Test Method	11
Qualification	12
Process Application Considerations	12
Gaskets and Seals: Conversion Considerations	12
HEALTH, SAFETY, AND ENVIRONMENTAL	13
General Safety Training	13
Material Safety	13
Hazards Common to Most Fluorocarbon Materials	13
Ingestion	14
Skin Exposure	14
Inhalation Exposure	14
Thermal Decomposition	14
Personal Protective Equipment – Solstice GBA	14
BULK STORAGE VESSELS	15
Minimum Requirements	15
Sub-systems Requirements	15
Level Measurements	15
Valves	15
Pumps	16
Gaskets	16
Pressure Relief Devices	16
Neat Solstice GBA Handling and Storage	16
Storage Vessel Inerting	16

BULK STORAGE VESSELS (CONTINUED)	
Tank Conversion Procedures	17
Solstice GBA Bulk Storage Tank Conversion	17
Polyol Blend Tank Conversion	18
SOLSTICE GBA PACKAGES	19
Cylinder Storage	20
Cylinder Return Instructions	21
Cylinder Markings	22-24
Cylinder Example Images	25-30
POLYOL (MASTER BATCH) BLENDING	31
Solstice GBA Polyol and Polymeric Methylene Diphenyl Diisocyanate (PMDI) Miscibility	32
Miscibility Test Procedure	32
Miscibility Table: Solstice GBA in Select Polyols and PMDI	32
Extruded Thermoplastic Foams	33
DRAWINGS	34
Descriptive Drawings & Schematics	35-41
APPENDICES	42
Vapor Pressure of Blowing Agent – English Units	42
Vapor Pressure of Blowing Agent – SI Units	43
Vapor Pressure Comparison Charts	44
REFERENCE NOTES	45

Introduction

Many extruded thermoplastic foam applications (i.e., extruded polystyrene) and select polyurethane and polyisocyanurate foam applications that used hydrochlorofluorocarbons (HCFCs) or hydrofluorocarbons (HFCs) are transitioning to Solstice® Gas Blowing Agent (GBA), also known as HFO-1234ze(E). It is the ultra-low global warming potential (GWP) blowing agent of choice. This is largely due to its environmental and performance properties.

This conversion manual has been developed as a part of Honeywell's commitment to a smooth transition to Solstice GBA. It has been designed to answer questions and to provide guidance on storage, handling, and processing of Solstice GBA in blowing agent applications. Chemical and physical property data, as well as related health and safety data for Solstice GBA are included in this manual. While this manual is intended to be thorough, it is not possible to cover every situation that may be found in all the manufacturing facilities around the world. Consequently, it is strongly recommended that the end user consult with qualified experts to assess their particular needs, including adherence to local, regional, national, and all other applicable codes and regulations when converting to Solstice GBA.

Solstice® Gas Blowing Agent (GBA) Overview

Solstice GBA is a hydrofluoro-olefin (HFO) with the chemical structure trans-1,3,3,3-tetrafluoropropene. Other nomenclature for Solstice GBA include: HFO-1234ze(E), (E)-1,3,3,3-tetrafluoroprop-1-ene, trans-1,3,3,3-tetrafluoroprop-1-ene, Solstice® 1234ze and Solstice® 1234ze(E). Hereafter in this document, Solstice GBA will be used in identifying this molecule. Solstice GBA is an ultra-low GWP replacement for HFC-134a, HFC-152a, HCFC-142b, and HCFC-22 in foam applications. Examples include polyurethane, polyisocyanurate, extruded polystyrene plank, pressurized polyurethane foams (one-component and two-component applications), and froth foams.

Solstice GBA exhibits very low GWP due to the double bond present in the carbon backbone and it is non-ozone-depleting. Solstice GBA exhibits several desirable attributes:

- Chemical and physical properties similar to HFC-134a and HFC-152a
- Ultra-low GWP. (GWP100 year < 1)
- No long-lived atmospheric breakdown products
- Non-flammable by U.S. DOT definition (reference 49 CFR 173.115)
- Non-flammable by ASTM E-681 (@23°C, ~1 atmosphere, 50% relative humidity) and EU A11 (@26°C, ~1 atmosphere) test methodologies
- Boiling Point of -2.2°F / -19°C
- Low order of toxicity, 800ppm 8-hour time weighted average (TWA) per U.S. Occupational Alliance for Risk Science (OARS) Workplace Environmental Exposure Level Guide (WEEL), 2012
- Compatible with commonly used metals, plastics, and elastomers
- Excellent polyol miscibility
- Good polymer melt solubility in polystyrene
- Superior foam properties, especially k-factor (lambda) and compressive strength

Due to these desirable attributes, Solstice GBA is ideally suited to replace HFCs and HCFCs in many foam insulation applications where superior environmental, flammability, and foam performance is demanded over hydrocarbons or other gaseous blowing agents, such as dimethyl ether (DME).

Specific technical data for Solstice GBA is included in the next section of this manual.

Solstice® GBA Technical Data

Physical and Chemical Properties

* These are but some of a mosaic of properties that must be evaluated in assessing candidate blowing agents.

Certain physical and chemical properties of Solstice GBA are shown in Table 1 (English Units) and Table 2 (SI Units)*. For comparative purposes, the properties of some other common currently or previously used blowing agents are also shown in Table 3.

Solstice GBA has properties which make this molecule an ideal low environmental impact blowing agent. It is non-flammable by ASTM E-681 (@23°C, ~1 atmosphere, 50% relative humidity) and by EU A11 (@26°C, ~1 atmosphere) test methodologies. The boiling point of Solstice GBA is such that this material is a liquefied gas under pressure and in practice, Solstice GBA is normally introduced into the foaming process in its liquid phase. Therefore, all processing equipment, metering (flow measurement), and mixing will be in the liquid phase and, as such, associated equipment should be configured for processing liquids (liquefied gas under pressure). Because the molecular weight* of Solstice GBA is moderately higher than HFC-134a, similar use levels can be realized in foam formulations. Solstice GBA is classified for transportation as a non-flammable liquefied gas under pressure. However, as with many materials, this molecule exhibits vapor flame limits at elevated temperatures, humidity, and/or pressures.

Low GWP materials, in the context of atmospheric lifetime, often prove to be volatile organic compounds (VOC) contributing to ground level ozone formation. The measure that characterizes whether a chemical is a VOC is the Maximum Incremental Reactivity (MIR). The MIR measure at which chemicals are generally considered to be a VOC is that of ethane. The MIR of Solstice GBA has been calculated to be approximately one-third the value for ethane¹.

¹ Reference:
Carter, W. P L., 2009,
"Investigation of
Atmospheric Ozone
impacts of Trans
1,3,3,3-Tetrafluoro-
propene."

Subsequently, Solstice GBA has been classified as VOC-exempt in the United States (U.S. EPA).

The European Union uses a somewhat different measure to characterize propensity for ground level ozone formation, namely photochemical ozone creation potential (POCP); "POCP is defined as the additional ozone formed in a multi-day modeling when adding a given amount of volatile organic compound relative to adding the same mass of ethene. The POCP scale is relative with the POCP for ethene defined as 100."² Solstice GBA has an estimated POCP of 6.4, which is significantly lower than the reference ethene.

² Reference:
T.J. Wallington a
Sulbaek
Andersen b, O.J.
Nielsen, 2015,
"Atmospheric
chemistry of short-
chain haloolefins:
Photochemical ozone
creation potentials
(POCPs), global
warming potentials
(GWPs), and ozone
depletion potentials
(ODPs)."

Temperature Considerations

Solstice GBA has a boiling point of -2.2°F (-19°C).

In extruded thermoplastic foaming operations, the operating conditions (pressure and temperature) of the polymer melt in the extruder are much higher than standard temperature and pressure (STP). Since the equipment designed for foam extrusion is typically capable of handling a blowing agent with similar physical properties to Solstice GBA, optimal extruded foam production is more dependent on the solubility of Solstice GBA into the polymer melt and the physical mixing capability of the individual extruder.

In polyurethane and polyisocyanurate foam systems, the vapor pressure that Solstice GBA exerts as part of the formulated system is very formulation dependent. Factors influencing the vapor pressure include temperature, the solubility of the blowing agent in the polyol(s), the concentration of the blowing agent in the blend, and the concentration and characteristics of the other ingredients in the formulation.

In a closed blending operation, the degree of inert loading in the vessel due to the presence of nitrogen will affect the pressure in the vessel significantly. As Solstice GBA is added to the blending vessel, the pressure in the blending vessel will initially rise until solution equilibrium with the polyol is achieved. Any inert gas loading in the vessel will be additive to the pressure exerted by the vapor pressure of Solstice GBA at the temperature of the system. In some cases, this inert gas loading may result in a pressure inside the vessel that exceeds the vapor pressure of neat Solstice GBA. A vapor pressure curve for Solstice GBA and selected blowing agents, as well as other additional properties, is included in the Appendices.

If Solstice GBA is introduced into a polyol blend that is at elevated temperature and/or added at a rate faster than the rate of dissolution into the polyol, there is some risk of a boiling liquid and expanding vapor frothing of the polyol blend. This risk must be recognized and necessary precaution exercised to not exceed this addition rate of Solstice GBA and to ensure proper mixing conditions.

Solstice GBA Physical Properties* – English Units

Temperature (°F)	Pressure (psia)	Liquid Density (lb/ft ³)	Vapor Density (lb/ft ³)	Specific Heat of Saturated Liquid at Constant Pressure (Cp) (Btu/lb°F)	Specific Heat of Saturated Vapor at Constant Pressure (Cp) (Btu/lb°F)	Heat of Vaporization (Btu/lb)
-40	5.3297	84.248	0.1377	0.29911	0.18579	89.173
-35	6.1699	83.796	0.15789	0.29995	0.18735	88.528
-30	7.1135	83.342	0.18038	0.30082	0.18892	87.879
-25	8.1695	82.885	0.20533	0.30174	0.19052	87.226
-20	9.3473	82.425	0.23293	0.30269	0.19214	86.566
-15	10.657	81.962	0.26339	0.30368	0.19379	85.901
-10	12.107	81.495	0.29691	0.30471	0.19547	85.228
-5	13.71	81.025	0.33371	0.30579	0.19718	84.549
0	15.476	80.552	0.374	0.3069	0.19894	83.862
5	17.416	80.074	0.41802	0.30806	0.20073	83.166
10	19.542	79.593	0.46603	0.30926	0.20256	82.461
15	21.865	79.107	0.51827	0.31051	0.20444	81.746
20	24.398	78.616	0.57502	0.3118	0.20636	81.021
25	27.153	78.121	0.63655	0.31315	0.20834	80.286
30	30.143	77.62	0.70316	0.31455	0.21038	79.538
35	33.382	77.114	0.77517	0.316	0.21248	78.779
40	36.882	76.603	0.85291	0.31752	0.21464	78.006
45	40.658	76.085	0.93671	0.3191	0.21687	77.22
50	44.723	75.562	1.0269	0.32076	0.21917	76.42
55	49.093	75.031	1.124	0.32248	0.22156	75.604
60	53.781	74.494	1.2283	0.3243	0.22404	74.772
65	58.802	73.949	1.3403	0.3262	0.22661	73.923
70	64.172	73.397	1.4604	0.32819	0.22928	73.056
75	69.905	72.836	1.5891	0.33029	0.23207	72.17
80	76.019	72.267	1.727	0.3325	0.23499	71.264
85	82.528	71.688	1.8747	0.33483	0.23804	70.337
90	89.45	71.098	2.0328	0.33728	0.24123	69.387
95	96.8	70.499	2.202	0.33987	0.2446	68.414
100	104.6	69.887	2.383	0.34261	0.24815	67.415
105	112.85	69.263	2.5766	0.34551	0.2519	66.389
110	121.59	68.626	2.7837	0.3486	0.2559	65.335
115	130.83	67.975	3.0054	0.35189	0.26017	64.25
120	140.58	67.308	3.2427	0.35541	0.26476	63.132
125	150.87	66.624	3.4968	0.35918	0.26974	61.98
130	161.72	65.922	3.7692	0.36325	0.27515	60.79
135	173.14	65.201	4.0612	0.36765	0.2811	59.56
140	185.15	64.458	4.3748	0.37244	0.28767	58.286
145	197.78	63.691	4.7119	0.3777	0.29499	56.965
150	211.05	62.898	5.0748	0.3835	0.30318	55.593
155	224.97	62.076	5.4663	0.38994	0.31242	54.164
160	239.58	61.222	5.8894	0.39718	0.32294	52.675

Table 1

* These are but some of a mosaic of properties that must be evaluated in assessing candidate blowing agents.

Solstice GBA Physical Properties* – SI Units

Temperature (°C)	Pressure (kPa)	Liquid Density (kg/m ³)	Vapor Density (kg/m ³)	Specific Heat of Saturated Liquid at Constant Pressure (Cp) (kJ/kgK)	Specific Heat of Saturated Vapor at Constant Pressure (Cp) (kJ/kgK)	Heat of Vaporization (kJ/kg)
-40	36.747	1349.5	2.2057	1.2515	0.77736	207.28
-35	47.685	1336.5	2.8143	1.2579	0.78912	204.57
-30	61.094	1323.3	3.5491	1.2648	0.80118	201.83
-25	77.355	1309.9	4.4279	1.2723	0.81361	199.05
-20	96.872	1296.4	5.4699	1.2803	0.82647	196.21
-15	120.08	1282.7	6.6961	1.2889	0.83984	193.31
-10	147.44	1268.7	8.1289	1.2981	0.85378	190.35
-5	179.42	1254.6	9.7928	1.3079	0.86837	187.31
0	216.55	1240.1	11.714	1.3185	0.88371	184.18
5	259.34	1225.4	13.923	1.3298	0.89988	180.96
10	308.36	1210.4	16.45	1.342	0.91702	177.63
15	364.16	1195	19.332	1.3553	0.93526	174.19
20	427.34	1179.3	22.607	1.3698	0.95479	170.63
25	498.52	1163.1	26.321	1.3856	0.9758	166.92
30	578.33	1146.4	30.523	1.4029	0.99857	163.06
35	667.41	1129.3	35.272	1.422	1.0234	159.02
40	766.45	1111.5	40.636	1.4431	1.0507	154.8
45	876.15	1093.1	46.693	1.4667	1.0813	150.36
50	997.22	1073.8	53.538	1.4932	1.1159	145.69
55	1130.4	1053.7	61.286	1.5234	1.156	140.74
60	1276.6	1032.5	70.078	1.5583	1.2036	135.48
65	1436.5	1010.1	80.093	1.5995	1.2613	129.87
70	1611	986.22	91.563	1.6493	1.3329	123.84

Table 2

*These are but some of a mosaic of properties that must be evaluated in assessing candidate blowing agents.

Physical Properties* - Continued

Property	HCFC-22	HCFC-142b	HFC-134a	Solstice® GBA
Chemical Formula	CHClF ₂	CH ₃ CClF ₂	CH ₂ FCF ₃	Trans CF ₃ CH=CFH
Molecular Weight	86	100	102	114
Boiling point @ 1 Atmosphere (°F)	-41.4	14.4	-14.9	-2.2
(°C)	-40.6	-9.8	-26.1	-19
Saturated Liquid Density				
@ 86°F (lb/ft ³)	73.09	68.48	74.13	71.57
@ 30°C (g/cm ³)	1.17	1.10	1.19	1.15
Specific Heat of Saturated Liquid at Constant Pressure (Cp)				
@ 86°F (Btu/lb °F)	0.31	0.32	0.35	0.34
@ 30°C (cal/kg °C)	310	320	346	335
Specific Heat of Saturated Vapor at Constant Pressure (Cp)				
@ 86°F (Btu/lb °F)	0.16	0.21	0.21	0.24
@ 30°C (cal/kg °C)	160	210	255	239
Latent Heat of Vaporization @ B.P., (Btu/lb)	100.49	92.52	93.35	84.43
(cal/g)	55.83	51.4	51.86	44.35

Table 3

*These are but some of a mosaic of properties that must be evaluated in assessing candidate blowing agents.

Flammability Considerations

Solstice GBA is classified as a non-flammable liquefied gas by the Globally Harmonized System of Classification and Labelling of Chemicals (GHS), United States Department of Transportation (DOT), International Air Transport Association (IATA), and International Maritime Dangerous Goods Code (IMDG) codes and regulations. A summary of flammability characteristics for Solstice GBA can be found in Table 4 on page 9.

Solstice GBA is designated as a Class 2 (non-flammable) Liquefied Gas per US DOT definition (49 CFR 173.115).

Flammability of Gases - Definitions and Measurement

The GHS defines a flammable gas as a gas having a flammable range in air at 20°C (68°F) and at a standard pressure of 101.3kPa (1 atmosphere). Similar definitions can be found in DOT, IATA, and IMDG codes and regulations.

Gases are considered to have a flammable range if they exhibit vapor flame limits, i.e., a lower flame limit (LFL) and an upper flame limit (UFL). The LFL is the leanest concentration of the gas in air that will support combustion and the UFL is the richest concentration in air that will support combustion.

Two of the commonly used tests to determine vapor flame limits are ASTM E-681 (@23°C, ~1 atmosphere, 50% relative humidity) and ISO 10156 (@20°C, ~1 atmosphere). Solstice GBA was tested according to both methodologies and found not to have a flammable range under the prescribed test conditions. Solstice GBA was also tested under EU Testing Method A11 (@26°C, ~1 atmosphere): Flammability of Gases and was found to be non-flammable.

However, Solstice GBA exhibits distinct and defined flame limits: LFL = 7.5 and UFL = 9.0 (volume percent in air) at one atmosphere under the following conditions:

- Temperature at 30°C, and
- Relative humidity \geq 50%, and
- High energy ignition source or open flame present

Minimum Ignition Energy

Another measure of flammability risk is minimum ignition energy (MIE). Solstice GBA exhibits a very high MIE, approximately 61,000 mJoules at a temperature of 54°C and a pressure of 1 atmosphere, which indicates that Solstice GBA is very difficult to ignite, even at this temperature.

Evaluating blowing agent storage vessels, polyurethane processing equipment, and extruded thermoplastic foam processing operations for flammability hazard and risk exposure is a function of both the flammable characteristics of the material and possible ignition sources. Open flames and sparks are clearly ignition sources. However, some common static electricity sources are often overlooked. The magnitude of energy from some common static electricity sources relative to the MIE at the LFL, for various alternate blowing agents is shown in Figure 1.

Minimum Ignition Energy at LFL @ ~20°C

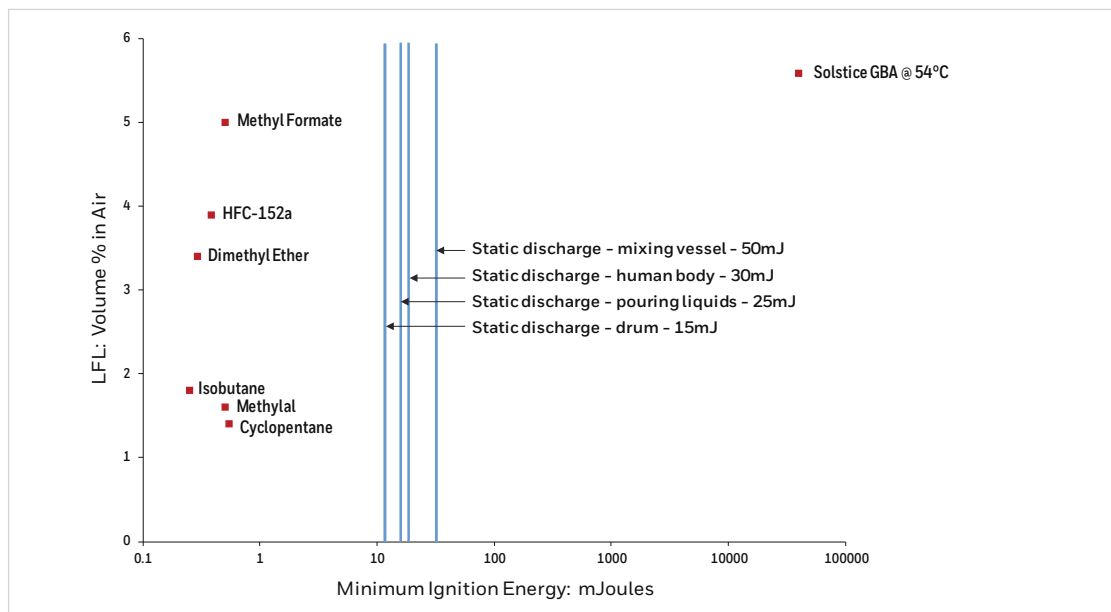

Figure 1

It is evident from this chart that there is low flammability risk with Solstice GBA blowing agent from any of these potential ignition sources.

Solstice GBA does not exhibit vapor flame limits in air until the temperature reaches 30°C. Solstice GBA MIE is measured at 54°C, at which temperature MIE is evident and is shown in Figure 1. In this regard, Solstice GBA is significantly less flammable than the other flammable materials as illustrated in Figure 1. Additionally, it should be noted that the MIE of Solstice GBA is orders of magnitude higher than the other flammable materials shown in Figure 1.

Most flammability characterization of Solstice GBA was performed by Chilworth Technologies Ltd. UK, with the finding, “It has been concluded beyond reasonable doubt that the material (Solstice® GBA) will not possess oxidizing or explosive properties.”

Solstice GBA Flammability Characteristics Summary

Test Methodology	Conditions	Results
ASTM E-681	23+/-3°C and 100+/-°C, 50% Relative Humidity, ~1 atmosphere	No Propagation Noted @ 23+/-3°C NOTE: flame propagation was observed at temperatures equal to and greater than 30°C
ISO 10156	20°C, ~1 atmosphere	Non-flammable gas
EU Testing Method A11 - Flammability of Gases	26°C, ~1 atmosphere	Non-flammable gas
EU Testing Method A15 - Auto Ignition Temperature (AIT)	~1 atmosphere	AIT = 368°C
Minimum Ignition Energy (MIE)	20°C 54-55°C	No Ignition Between 61,400 and 64,200mJ

Table 4

Materials Compatibility

Solstice GBA is non-reactive and non-corrosive toward most commonly used metals in polyurethane, polyisocyanurate, and thermoplastic processing equipment. This includes carbon steel, stainless steel, copper, and brass. One should exercise caution with the use of aluminum due to its highly reactive nature in contact with any halogenated material, which includes Solstice GBA, particularly if aluminum fines are present. This is especially true if the oxide layer on the surface of the aluminum is removed. While it is acceptable to use copper and copper alloys for neat Solstice GBA, it is not recommended these materials be used with fully formulated polyurethane and polyisocyanurate systems.

In general, Solstice GBA is similar in compatibility toward plastics and elastomers as HFC-134a. Gaskets and seals that were changed to accommodate HFC-134a should be compatible with Solstice GBA. Honeywell has evaluated plastics and elastomers for use with Solstice GBA. Table 5 reports the findings of this study. For ease of reference, the material compatibility of HFC-134a is also included in Table 6. Elastomers that may find application in both static conditions (for example, gaskets between flanges) versus dynamic conditions (for example, seals on rotating shafts) may have varying degrees of suitability in use.

Solstice GBA Materials Compatibility

Substrate	Average Percentage Change			Comments
	Hardness	Weight	Volume	
Plastics				
ABS	-	+0.21	-0.60	
Acetal	-	+0.18	+0.48	
Acrylic	Extremely distorted substrate			Pitted after 1 wk, expands
HDPE	-	+0.82	-3.74	
Nylon 6,6	-	-0.26	0	
Polycarbonate	-	+1.10	+0.77	Turbid fluid after 1 wk, residue
Polyetherimide	-	-0.04	0	
PVDF	-	+0.21	0	Fluid discoloration
PTFE	-	+2.03	+2.43	
Polypropylene	-	+0.83	0	Turbid fluid, residue
HIPS	-	+0.26	-0.45	
PVC-TYPE 1	-	+0.002	-0.44	
PET	-	-0.01	0	
PEEK	+1.01	-0.02	-0.14	
Elastomers				
SBR/CR/NBR	+7.28	+2.00	-4.31	
Fluoroelastomer	-11.29	+4.43	+5.71	
Buna-nitrile	+8.91	-4.95	-7.18	
EPDM	-1.50	-2.00	-2.49	
Epichlorohydrin	-3.50	+0.73	+1.51	
Silicone	-0.71	-1.57	-1.96	Slight fluid discoloration, residue
Natural (Gum)	+2.00	-0.64	-0.75	
TPU	-4.35	+5.14	+4.41	
Butyl Rubber	-1.13	+1.27	+0.88	
Neoprene	+7.32	-7.70	-11.47	
Perfluoroelastomer	-10.36	+5.22	+33.00	

Table 5

HFC-134a Materials Compatibility

NOTE:

S=Suitable

Su=Suitable with some exceptions

U=Unsuitable

Us=Unsuitable with some exceptions.

Material	Suitability
Ethylene Propylene Diene Terpolymer	S
Ethylene Propylene Copolymer	S
Chlorosulfonated Polyethylene	S
Polyisoprene	S
Chlorinated Polyethylene	Su
Neoprene	S
Epichlorohydrin	S
Polyvinylidene fluoride and copolymer of vinylidene fluoride and hexafluoropropylene	U
Silicone	Us
Polyurethane	S
Nitrile	Su
H-NBR	S
Butyl Rubber	S
Natural Rubber	Su
Polysulfide	S
Nylon	S
PTFE	S
PEEK	S
ABS	S
Polypropylene	Su
Polypropylene Sulfide	Su
PET	S
Polysulfone	S
Polyimide	S
Polyetherimide	S
Polyphthalamide	S
Polyamideimide	S
Acetal	S
Phenolic	S
Epoxy Resin	S

Table 6

Compatibility Test Method

- Test coupons were cut to a one-inch length and one half-inch width.
- Initial weight of the individual test coupons was determined.
- Test coupons were placed in sealed vials. The vials were filled with Solstice GBA and capped. Note that most test coupons' densities were less than the density of Solstice GBA such that the test coupon floated in the vial.
- Exposure time was 14 days at room temperature.
- After exposure, the test coupons were removed from the vials and allowed to dry by evaporation for two minutes.
- Final weight and dimensions of each test coupon was determined and reported.

Qualification

The information presented in Table 5 should be considered in the context of the evaluation that was performed. It must also be recognized that within the same family of plastic or elastomer, there may be many different manufacturers of these materials, and many different grades and quality of materials. Typically, a single material from each generic type was tested. This material may or may not be representative of the class of material, but was one that is known to be used in this class of materials.

Process Application Considerations

The final determination of suitability for use is the responsibility of the end user. Please see Table 5 for materials compatibility information.

Prudence and consideration of the following three statements will dictate decisions on gasket and seal changeout for use with Solstice GBA.

Gaskets and Seals: Conversion Considerations

- What is the risk exposure if the gasket/seal fails in terms of safety, environment, and economics?
- Compatibility with neat Solstice GBA does not predict compatibility with polyurethane or polyisocyanurate premixes containing Solstice GBA.
- In the absence of specific compatibility data, PTFE is the recommended alternative.

Health, Safety, and Environmental

The Safety Data Sheets (SDS), previously known as material safety data sheets (MSDS), for Solstice GBA (Solstice 1234ze) accompany all shipments. These data sheets can be viewed by accessing www.honeywellmsds.com. Additional copies can be obtained by contacting Honeywell at: **1-800-522-8001** or your local Honeywell office.

Solstice GBA has progressed through a battery of toxicity testing for human health effects. The Honeywell SDS for Solstice GBA contains comprehensive and the most current detail for the health, safety, and environmental aspects and considerations.

This section contains a generic fluorocarbon safety training module for Solstice GBA. This information can be utilized for in-plant safety meetings and general training seminars for employees working with Solstice GBA. This module supplements, but does not replace, the SDS. Should you desire Honeywell's assistance in this regard, contact your Honeywell representative or Honeywell's Blowing Agent Technical Service group: **1-800-631-8138** (option 2, then option 2 again).

General Safety Training

Material Safety

The SDS is the most important document to accompany Solstice GBA.

- Read the SDS
- Ask for clarification if you do not understand
- Keep the SDS in a prominent location near the use area
- Follow any and all other requirements your company may have regarding SDS's, including, but not limited to training, periodic review, etc.

Hazards Common to Most Fluorocarbon Materials

- Overexposure: Symptoms include but are not limited to dizziness, nausea, drowsiness, and may lead to unconsciousness.
- At higher levels (displacement of oxygen to <15%):
 - Central nervous system depression
 - Cardiac arrhythmia
 - Asphyxiation
 - Loss of coordination
 - Increased pulse rate and deeper respiration
- Inhalation of high concentration of vapor can lead to cardiac arrhythmia
- Because of possible disturbances of cardiac rhythm, heart stimulating drugs such as adrenaline (epinephrine) should be used with special caution and only in situations of emergency life support.
- Treatment for overexposure should be directed at the control of symptoms and clinical conditions
- Rapid evaporation of the liquid may cause frostbite
- Seek medical assistance

Ingestion

- Ingestion is unlikely because of the low boiling point of the material. Should it occur, discomfort in the gastrointestinal tract from rapid evaporation of the material and consequent evolution of gas would result. Some effects of inhalation and skin exposure would be expected.
- Call a physician if irritation develops or persists
- If conscious, have victim swallow two glasses of water. Do not induce vomiting unless instructed to do so by a physician. Seek medical assistance.

Skin Exposure

- Rapid evaporation of the liquid may cause frostbite
- If there is evidence of frostbite, bathe (do not rub) with lukewarm (not hot) water. If water is not available, cover with a clean, soft cloth or similar covering.
- Call a physician if irritation develops or persists

Inhalation Exposure

- Immediately remove to fresh air
- If breathing has stopped, give artificial respiration
- If breathing is difficult, have qualified person give oxygen
- Seek medical attention for irritation or other symptoms

Thermal Decomposition

- Fluorocarbons contain halogens (fluorine) and should not be exposed to open flames
- Avoid contact with strong oxidizing agents and with finely divided white metals such as magnesium, aluminum, and zinc
- Thermal decomposition of HFOs, including Solstice GBA, generates toxic and corrosive materials
- Possible thermal decomposition products include halogen acids, carbon oxides, and carbonyl halides
- HFOs, such as Solstice GBA, cannot form phosgene. They can form carbonyl halides.

Be familiar with procedures for response to skin or eye contact. Eye wash and safety shower are recommended. Typically, remove affected clothing, flush area with water for at least 15 minutes, lifting eyelids occasionally to facilitate irrigation. Seek medical attention.

Personal Protective Equipment – Solstice GBA

- **Skin protection:** Use protective impervious, chemical resistant gloves and clothing.
- **Eye protection:** Wear chemical resistant safety goggles.
- **Respiratory protection:** None required if used within ventilated process enclosure. Use NIOSH approved self-contained, positive pressure respirators for emergencies and in situations where air may be displaced by vapors.

Bulk Storage Vessels

Minimum Requirements

Storage of Solstice GBA (liquefied gas) will require a pressure vessel due to the potential for vapor pressure generation in the tank at ambient storage temperatures. Honeywell engineering guidance for bulk storage of Solstice GBA is:

** Alternatively, at a minimum, storage tanks should be designed to have a rating for the vapor pressure of HFO-1234ze(E) at 130°F (54°C) plus a 10% safety factor for safety device tolerances.*

- Storage vessels nominally should preferably be rated at a minimum of 250 psig (1724 kPa).^{*} Proper safety relief device(s) should be installed and sized appropriately.
- Storage vessels should be designed for full vacuum or have vacuum breakers installed
- Carbon steel is the recommended material of construction
- Pressurization or inerting of the tank must only be done with an inert gas such as dry nitrogen. Air should not be considered for use.
- Check all applicable code and regulatory requirements to ensure compliance if applicable

Generally, storage tanks range in size from 6,565 gallons or 24,851 liters (tank truck deliveries) to 30,000 gallons or 113,562 liters (rail car deliveries). Individual manufacturing locations should be evaluated for the most practical tank size for installation. Parameters to be considered should be consumption rates, available space, economics, and proximity to supply point.

Complete pre-engineered bulk storage systems range in sizes up to 12,000 gallons (45,425 liters). Standard sizes are 6,565 (24,851 liters), 9,200 (34,826 liters), and 12,000 gallons capacity. These packaged units consist of a storage tank, dual pumps (one of which is a dedicated spare), level gauge, filters, starter motors, piping, completely assembled and shipped via flatbed truck for installation on a concrete pad. Larger storage tanks will require foundations and pillars for support and are considerably more involved with respect to labor and material costs.

All storage tanks should be built in accordance to the latest edition of ASME Code, Section VIII, must have a “U” stamp, and must be National Board registered. Outside of the United States, the equivalent engineering pressure vessel code should be applied.

Sub-systems Requirements

Level Measurements

A variety of level measurement devices are commonly in use for determining the level in the storage vessel. Some of the most common and least expensive are level sight glasses and float gauges with a % full dial (Standard 0-100% Scale). Use of these is limited to determining the point at which another delivery is required, and not normally used for inventory purposes. For accurate inventory control, load cells are recommended. More sophisticated instruments can provide exact temperature and level measurements simultaneously for more accurate determination of the amount of product in the vessel (Float / Temperature device). Redundant level instruments are not uncommon in the event one of the units malfunctions or fails.

Valves

Full port ball valves with PTFE seats and seals, carbon steel body, and stainless steel ball and stem are recommended. Gate valves with appropriate packing and adjustable packing gland are suitable for use.

Pumps

Turbine, diaphragm, side channel multi-stage, sliding vane, or centrifugal pumps with casing pressures to match ANSI 150# class ratings are used to deliver Solstice GBA blowing agent to the polyol blend tank. These pumps should utilize PTFE mechanical seals or be seal less and magnetically coupled and driven. Consideration should be given to the installation of 2 pumps in a parallel configuration and sized properly for desired differential pressures and flow rates. Also, consideration should be given to the net positive suction head required (NPSHr), suction side strainers, and discharge side check valves.

Gaskets

Stainless steel spiral wound with PTFE filler are recommended. Other types of gaskets such as stainless steel reinforced flexible graphite, flexible graphite, stainless steel reinforced PTFE, and 1/8" (3 mm) PTFE sheet are adequate. Before using gaskets or other elastomeric materials, refer to the compatibility chart (Table 5) earlier in this guide. Consideration of the risk exposure should the gasket fail is the prudent guidance on these choices.

Pressure Relief Devices

Storage tanks must be protected against excessive pressure. A positive sealing valve or a rupture disc and a spring-loaded relief unit is recommended. Satisfactory materials for the rupture disc include MONEL™, nickel, stainless steel, and silver. Relief valves used after a rupture disc can be carbon steel construction. The pressure relief device setting should equal the vessel pressure rating.

Neat Solstice GBA Handling and Storage

From the Honeywell bulk delivery trailer, through the Solstice GBA bulk storage tank to the polyol blend tank (master batch tank) or the extrusion operation, the material stream is neat Solstice GBA (liquefied gas). All handling and processing operations with respect to the pressure ratings of vessels, gasket, and seal material compatibility, and all safety precautions relate directly to Solstice GBA.

With respect to thermoplastic extrusion operations, the material is neat Solstice GBA (liquefied gas) up to the point the material enters the extruder.

Storage Vessel Inerting

Although it is recognized that there are specific applications that require putting an inert blanket of dry nitrogen on the Solstice GBA storage vessel, Honeywell generally recommends against this practice whenever possible as it can create issues with the delivery trailers during Solstice GBA off-loading.

If an inert atmosphere is required on a vessel, Honeywell recommends that dry nitrogen be utilized.

Air must not be used. Even though a fluorocarbon, such as Solstice GBA, is non-flammable, fluorocarbons combined with air or oxygen under elevated pressure and/or temperature can become flammable under certain conditions.

CAUTION: *If Solstice GBA is introduced into a polyol that is at elevated temperatures, or if the polyol blend tank has a high level of inert loading, such as nitrogen, excessive pressures on the polyol blend tank can be achieved. This is due to the Solstice GBA being vaporized by the hot polyol prior to complete dissolution, and/or the vapor pressure of the Solstice GBA being additive to the pressure exerted by the inert loading in the vessel. The best practice is to allow little or no inert loading on the polyol blend tank.*

Individual operations should choose design criteria for equipment commencing with the polyol blend tank through to the foam head on the basis of polyol blend physical and chemical characteristics or experience. Risk assessment and understanding the worst case scenario is the prudent guidance for decisions relative to this section of the process.

Tank Conversion Procedures

Solstice GBA Bulk Storage Tank Conversion

- Determine tank suitability for Solstice GBA:
 - Obtain a set of tank drawings that identify tank and design criteria
 - Check ASME Data Plate – Pressure / Vacuum Rating
 - Material of Construction – Carbon Steel
- Conduct tank inspection externally:
 - Look for evidence of external corrosion – may affect pressure rating
 - Check tank shell, tank nozzles, support saddles
 - Use ultrasonic thickness gauge to determine shell corrosion
- Remove liquid (HFC-134a or other material) to auxiliary tank
- Remove vapor with vacuum pump to 29" vacuum
- Introduce dry air (dew point = -40°F) to atmospheric pressure
- **Use extreme caution if internal inspection is planned.** A confined space presents potential physical and chemical hazards. If a vessel is to be entered, use a recognized confined space entry procedure. Please check with your company's safety department prior to entering any tank or vessel.
- Change all gaskets to compatible gasket material
- Change all valves as indicated by compatibility assessment
- Conduct preventative maintenance and test on safety relief valves
- Pressurize tank with dry air or dry nitrogen to 50 psig to check for leaks
- Evacuate tank to 29" vacuum
- Change pump seal if indicated by compatibility testing
- Change all gaskets from pump to polyol blend tank as indicated
- Inspect and change valves from pump to polyol blend tank as indicated
- Repair/replace all grounding straps from bulk storage tank to polyol blend tank

Judicious inspection and maintenance of the bulk storage tank system during the conversion to Solstice GBA will minimize the risk of failure in the future. Honeywell representatives are available to provide assistance through the conversion process.

Polyol Blend Tank Conversion

- Determine suitability of tank for polyol preblends containing Solstice GBA:
 - Obtain tank drawings and pressure rating
 - Test polyol blend to determine tank pressure requirements
- Inspect tank, internally and externally, for corrosion
- Inspect/repair the internal tank liner if one is present
CAUTION! Tank entry by personnel may be considered a "confined space entry" by your company. Specific safety rules and procedures may exist. Please check with your company's safety department prior to entering any tank or vessel.
- Ensure that Solstice GBA will be introduced below liquid level in the blend tank. If Solstice GBA addition is above the liquid level, install a dip-leg below the liquid level, or re-pipe the Solstice GBA addition to a different tank nozzle that is below the liquid level.
- Assess and change gaskets and valves as indicated by polyol blend compatibility requirements
- Service and/or test safety relief system on the blend tank
- Assess and change pump seals as indicated by polyol blend compatibility requirements
- Assess and change agitator seal as indicated by compatibility requirements.
CAUTION! A robust seal arrangement to accommodate high pressures should be installed for the agitator shaft seal.
- Inspect polyol blend circulation cooling/heat exchanger
- Repair/replace all grounding straps

Storage tank conversion to Solstice GBA provides an ideal opportunity for a thorough inspection and maintenance to avoid risk of failure in the future. Inspection and preventative maintenance in a like fashion should be performed from the polyol blend tank through any auxiliary equipment to the foam head during the conversion to Solstice GBA.

Solstice GBA Packages

Solstice GBA is supplied in a variety of packages including cylinders and isotainers. Before handling or using Solstice GBA, carefully review the information in the Honeywell SDS. Copies of the SDS may be obtained by contacting Honeywell at **1-800-631-8138**, or **1-800-522-8001** (Fluorine Products) within the U.S. and Canada, or by contacting the local Honeywell sales office. The SDS may also be viewed online at the Honeywell MSDS Resource Center: www.honeywellmsds.com.

All packages comply with all applicable codes and regulations for the regions in which they are transported. Honeywell supplies packages globally from various sites. Globally, package sizes, configurations, and cylinder return sites will vary from the U.S. In addition, countries outside the U.S. may have different requirements for the SDS for Solstice GBA. Customers are advised to contact their local Honeywell sales office for this information.

Honeywell has established a variety of standard packages for Solstice GBA. Typical package sizes for Solstice GBA are found in Table 7. These are subject to availability and change.

Typical Solstice GBA Package Sizes

Region(s)	Description / actual fill wt.	Package size	Fitting type/size	Dimensions
Global	10lb/4.5kg Returnable Cylinder	10lb	1/4" flare liquid and vapor	7.5"D x 14.75"H
Global	10lb/4.5kg Non-returnable Cylinder	10lb	1/4" flare	8"D x 15"H
Global	44lb/20kg Returnable Cylinder	50lb	1/4" flare liquid and vapor	22.5"D x 19"H
Global	110lb/50kg Returnable Cylinder	100lb	CGA 660 liquid, 1/4" flare vapor	48"H x 10"D
Global	1000lb/454kg 1/2-Ton Returnable Cylinder	½ Ton	CGA 660 liquid and vapor	56"H x 31"D
Global	1700lb/771kg Ton Returnable Cylinder	Ton	CGA 660 liquid and vapor	82"L x 30"D
Global	28,000-34,000lb (12,700-15,422kg) Returnable Isotainer Tank	ISO	3.25" Acme liquid and 1.75" Acme vapor	20'L x 8'W
EMEAI*	5kg Returnable Cylinder	5kg	DIN 477-6 liquid	13.8"H x 9"D
EMEAI*	50kg Returnable Cylinder	50kg	DIN 477-6 liquid	45"H x 12"D
EMEAI*	50kg Returnable Cylinder Pressurized with Nitrogen	50kg	DIN 477-6 liquid	45"H x 12"D
EMEAI*	890kg Roll Drum (RD)	Ton	5/4" BSW thread	88"L x 31.5"D
EMEAI*	890kg Cylinder Pressurized with Nitrogen	Ton	5/4" BSW thread	88"L x 31.5"D
EMEAI*	12,700-15,422kg (28,000-34,000lb) Returnable Isotainer Tank	ISO	3.25" Acme liquid and 1.75" Acme vapor	20'L x 8'W
Canada	110lb/50kg Returnable Cylinder	100lb	CGA 660 liquid, 1/4" flare vapor	48"H x 10"D
Canada	30lb/13.6kg Returnable Cylinder	30lb	1/4" flare liquid and vapor	17.4"H x 9.2"D

Table 7

*EMEA: Europe, Middle East, Africa and India

CAUTION: Only dry nitrogen should be used to pressurize Solstice GBA cylinders. Air should never be used.

These packages are pressure vessels with safety relief devices installed on them. Contact your local Honeywell office for package sizes and availability specific to your region. For your reference, we have included images of typical packages (see Figures 7-16).

The service pressure of these cylinders varies, but all meet a minimum maximum allowable working pressure (MAWP) of 260 pounds per square inch (psi), 1800 kilopascals (kPa). A schematic for nitrogen pressurization supply piping is included in the Drawings section (see Drawings 7-8). Furthermore, where blue arrows indicate vapor valves on the cylinder images, this represents where nitrogen would be added. Most packages can be pressurized with nitrogen, however, European 5kg, European 50kg returnable cylinders, and the Global 10lb/4.5kg non-returnable cylinder cannot be pressurized.

Specific details and specifications with drawings for some of these packages are included in the Drawings section (see Drawings 1-8). Care must be exercised in orienting horizontal one-ton cylinders such that the valves are in the vertical orientation.

Cylinders can be identified by the following information stamped on the cylinder:

- Owner's name (Honeywell)
- Regulatory specification number for the cylinder (DOT, TC, etc.)
- Serial number
- Date of test, month, and year
- Manufacturer's symbol
- Water capacity in pounds

For your assistance, we've provided guidance on how to interpret cylinder markings (see Figures 3-6).

Some cylinder sizes described are returnable, and should be returned to Honeywell. For cylinder returns, please contact your local Honeywell account representative or Honeywell customer service.

For the U.S., please follow the cylinder return instructions on the next page (Figure 2).

Cylinder Storage

Store Solstice GBA packaged cylinders in a dry, ventilated, enclosed area away from heat, flame, corrosive chemicals or fumes, and explosives. Avoid direct sunlight, particularly in warm weather.

Do not allow a cylinder to get warmer than 122°F (50°C). Solstice GBA cylinders should always be raised above dirt or damp floors to prevent rusting. All containers must be secured in place by means of a rack or chain, so they cannot tip, roll, or accidentally strike each other or any other object.

Cylinder Return Instructions (Continental U.S.A.)

1

Provide Information

- Number and size of cylinders
- Product last contained

2

Contact Schneider Logistics at 1-866-681-5160

- Schedule pick up and provide Bill of Lading

3

Review

- Is the Bill of Lading accurate?

4

Shipment Requirements and Freight

Affix Tags

- DOT tags are required for **every** cylinder
- DOT hazmat information contained on the product label must be legible
- When returning a damaged cylinder an **additional** "Return for Inspection" tag is required
- For additional tags contact Schneider Logistics (1-866-681-5160)

Palletize Cylinders

- All cylinders must be properly palletized

Instructions for Damaged Returns

- Disposable cylinders must be in original carton which contains all of the required DOT information
- Shrink wraps and seals must be intact
- All approved product credits will be applied within 30 business days of cylinder receipt

Freight

- Freight prepaid by Honeywell provided minimums are met
- Minimums do not apply to damaged cylinders

Minimum Return Requirements

Cylinder Size	Number of Cylinders
Ton	1
½ Ton	1
200 lb cylinder	9
100-125 lb cylinder	12
50 lb cylinder	24
25 lb cylinder	40
10 lb cylinder	40

Damaged cylinders can be combined with empties

NOTE: Full or partial cylinders containing a Class 2.1 (flammable gas) must be secured and transported vertically

Honeywell Customer Service: 1-800-522-8001 / fpcustomer@honeywell.com

Figure 2. How to Return Empty and Damaged Cylinders for Honeywell Refrigerants, Blowing Agents, Aerosols and Solvents (Continental USA Only)

Cylinder Markings – UN Pressure Receptacles

What types of markings appear on UN pressure receptacles?

TOP ROW

Contains manufacturing marks such as the cylinder thread type, the country of manufacture, and the serial number assigned by the manufacturer.

MIDDLE ROW

Contains operational marks such as the test pressure, the tare or empty weight, and the minimum wall thickness.

BOTTOM ROW

Contains certification marks such as the UN packaging symbol, the ISO standard, the country or countries of approval, and the manufacturer's approval mark.

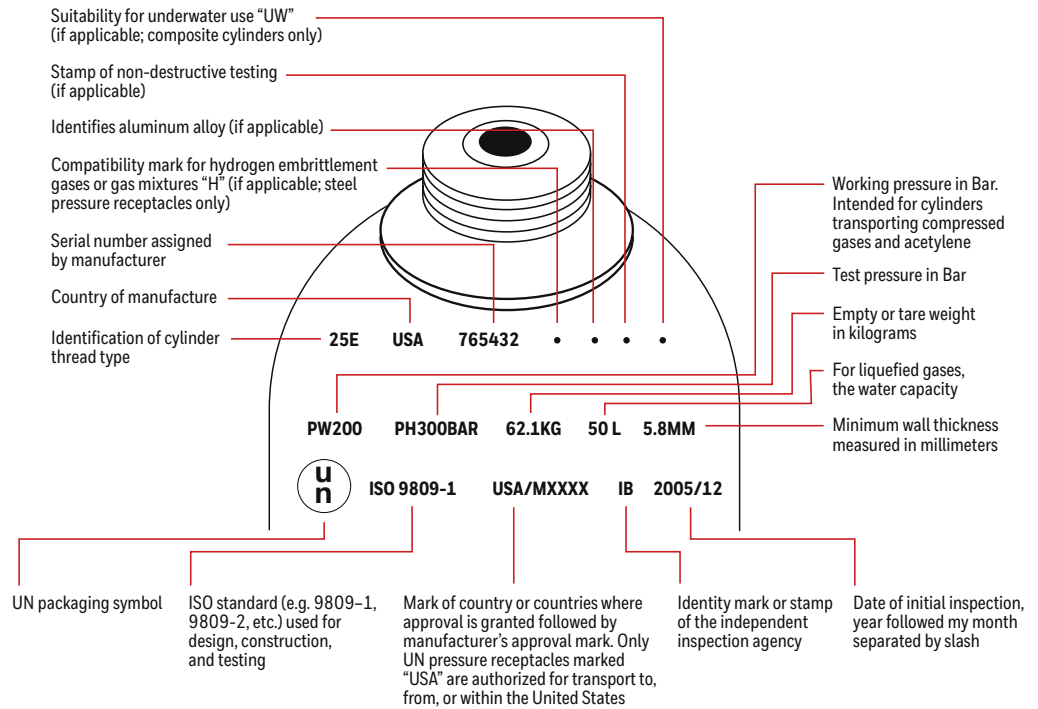

Other markings are permitted in other low stress areas provided they are not on the side wall. The markings must not conflict with the required markings.

Figure 3

Cylinder Markings - Canada

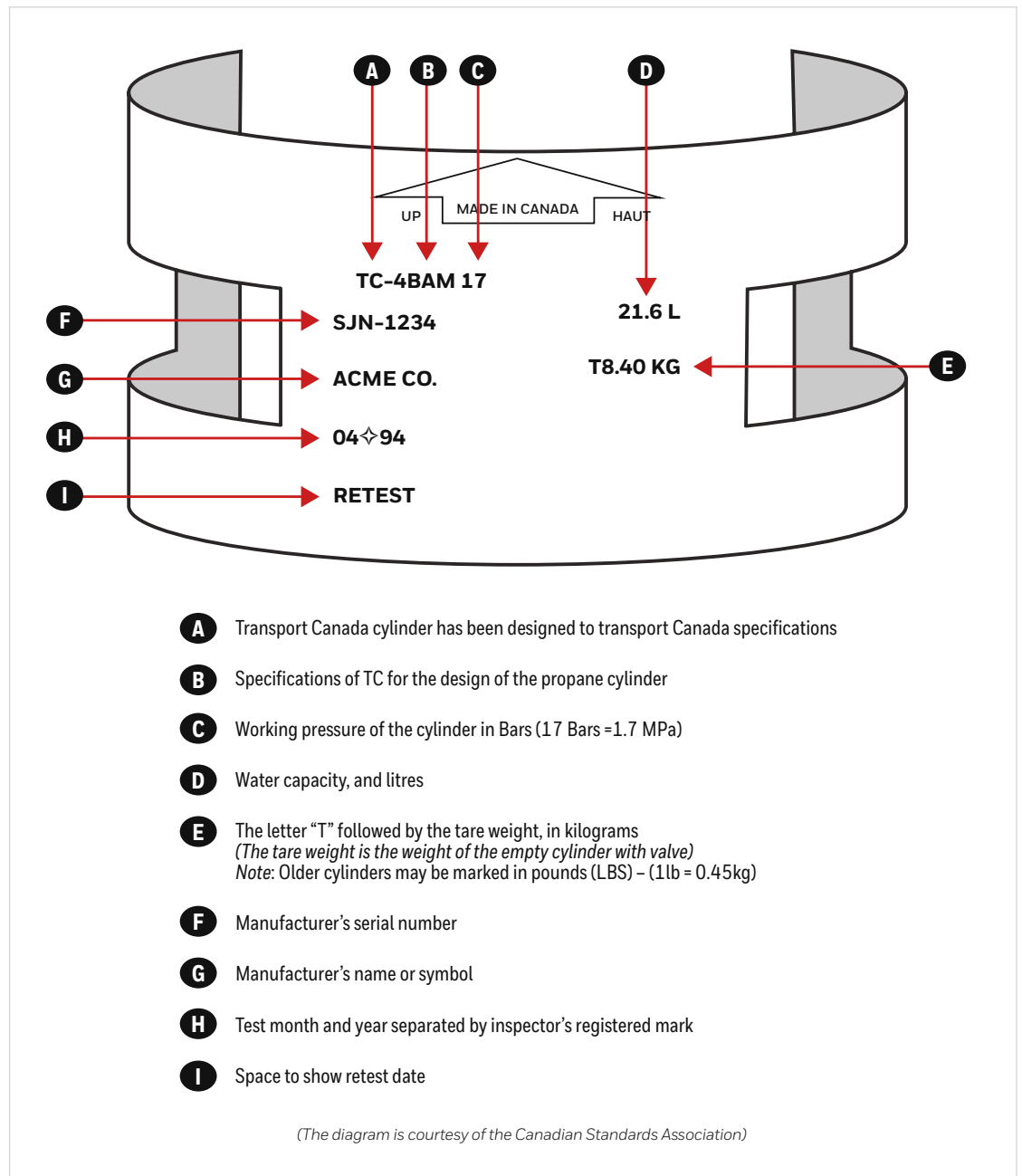

Figure 4

Cylinder Markings US DOT



Figure 5

Cylinder Example



Figure 6

Solstice GBA 10lb/4.5kg Returnable Cylinder

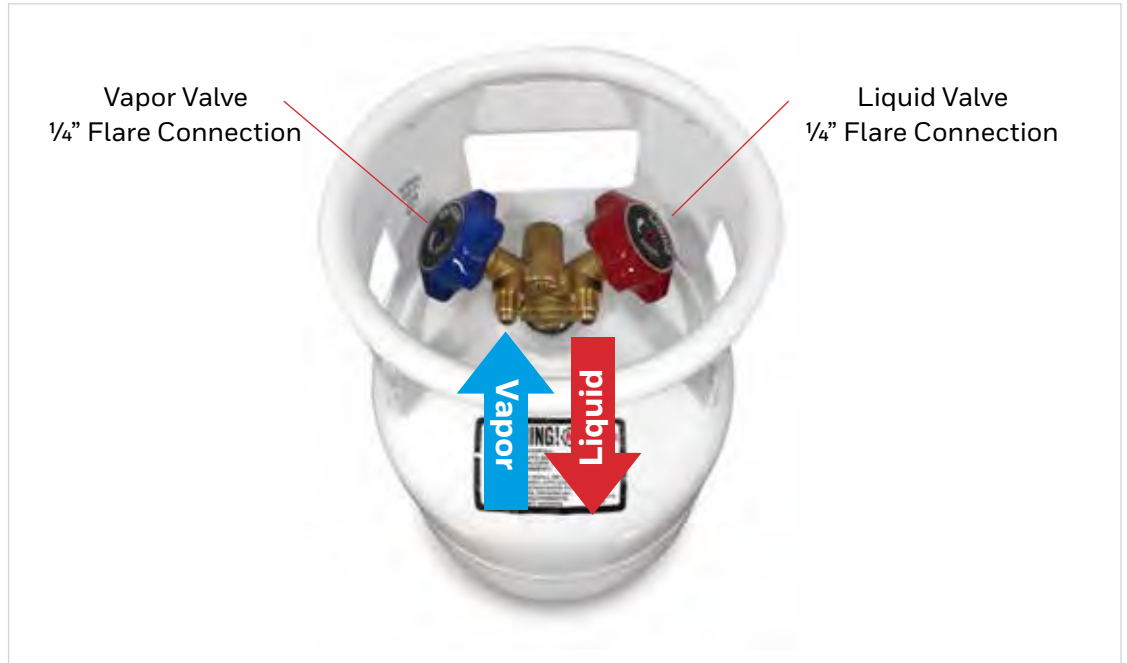

Figure 7. Global except EMEA and Canada

Solstice GBA 10lb/4.5kg Non-Returnable Cylinder

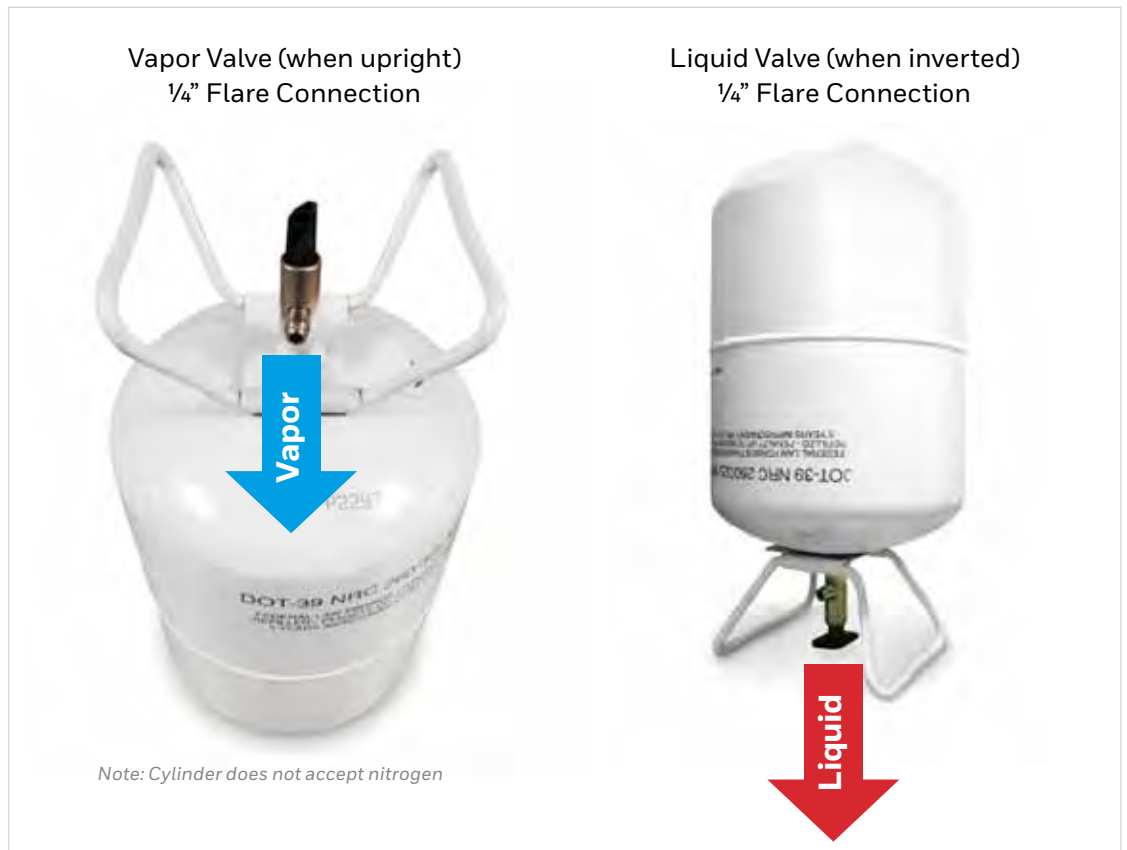

Figure 8. Global except EMEA and Canada

Solstice GBA 44lb/20kg Returnable Cylinder

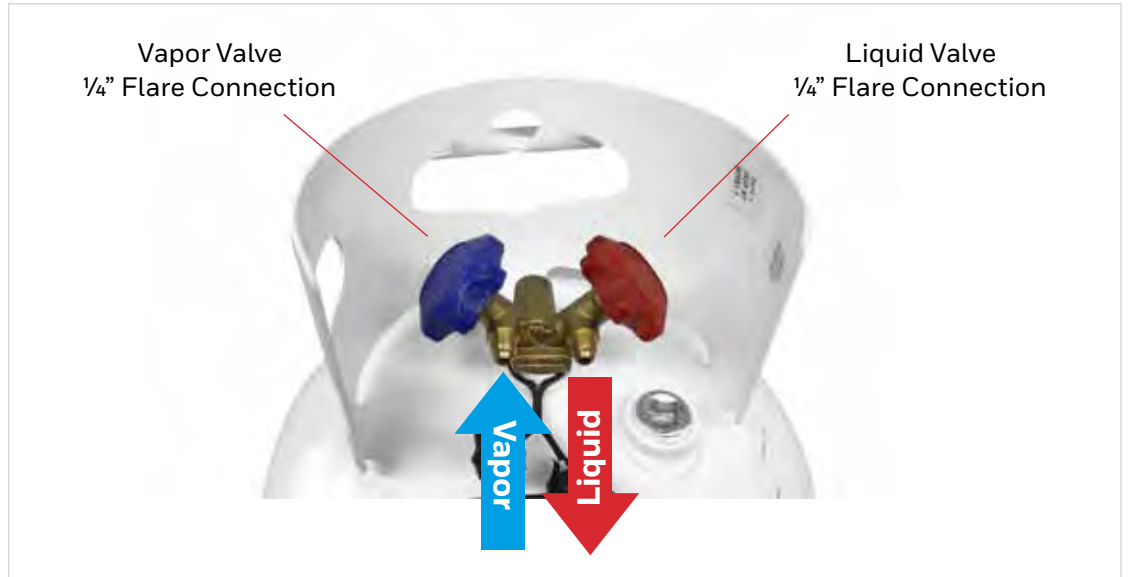

Figure 9. Global except EMEA and Canada

Solstice GBA 110lb/50kg Returnable Cylinder

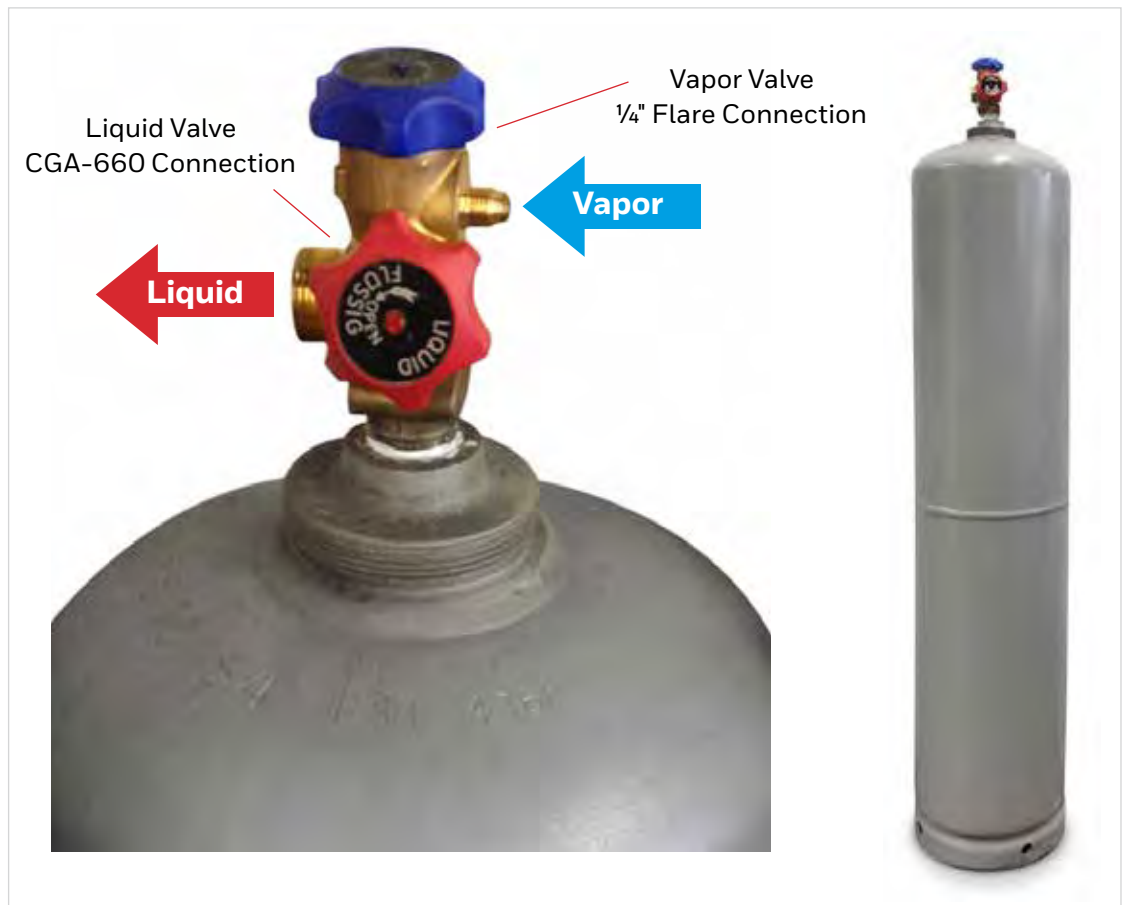

Figure 10. Global/Canada except EMEA

Solstice GBA 1000lb/454kg ½ Ton Returnable Cylinder

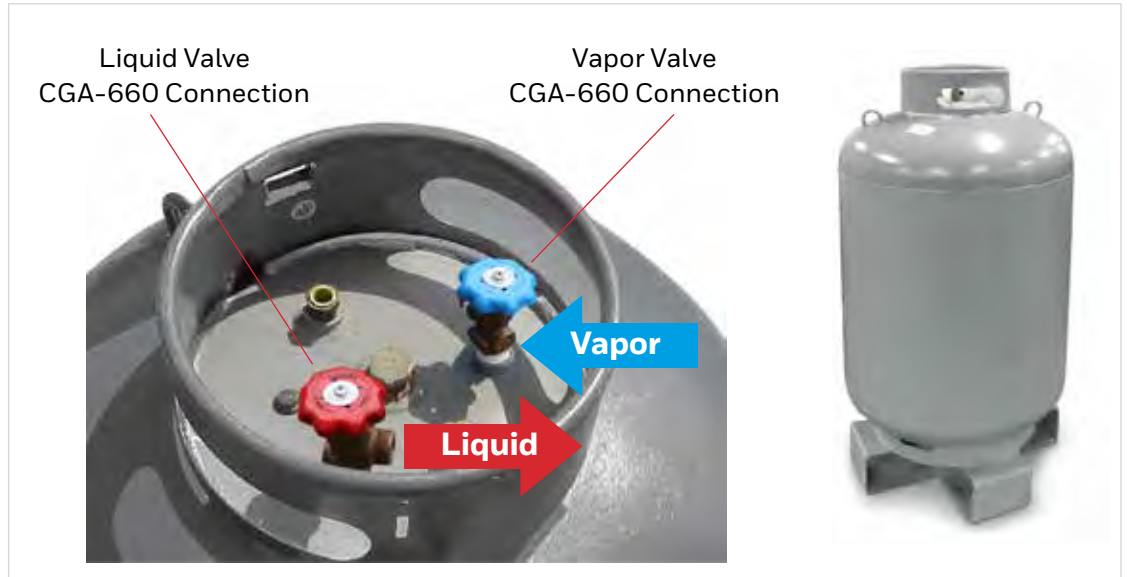

Figure 11. Global except EMEAI and Canada

Solstice GBA Ton Returnable Cylinder

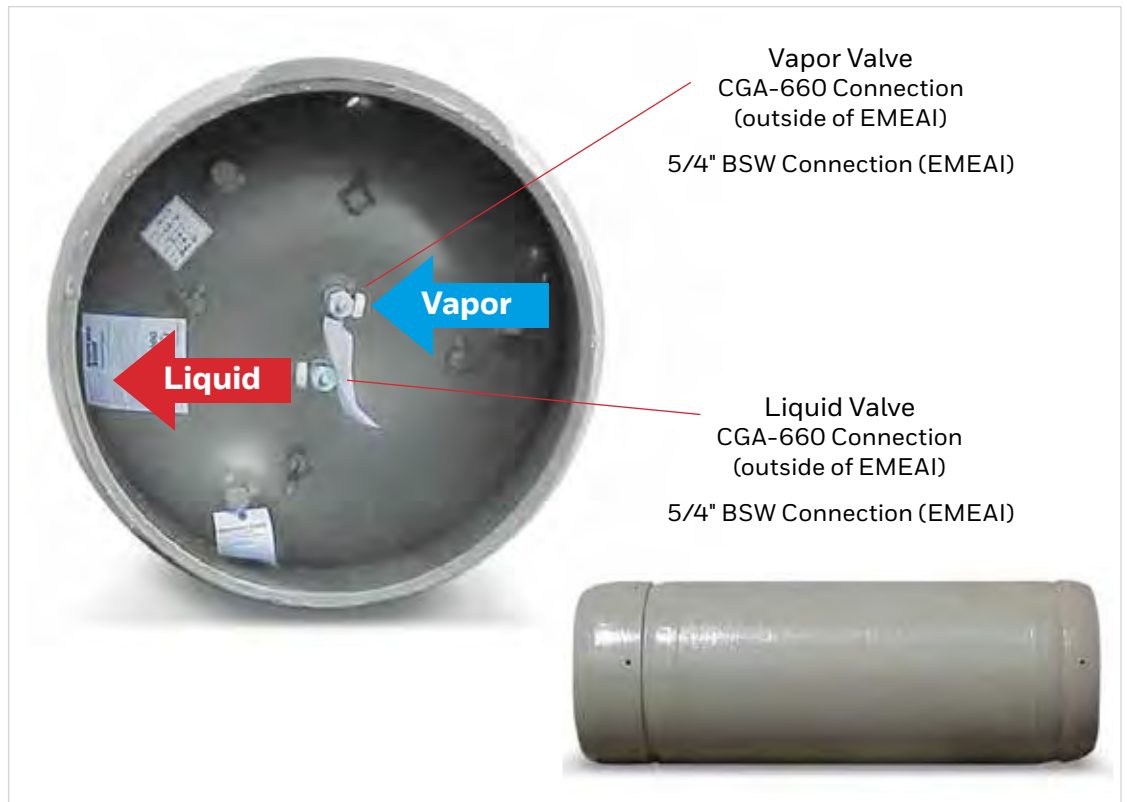

Figure 12. Solstice GBA 1700lb/771kg Ton Returnable Cylinder (Global/Canada except EMEAI)
Solstice GBA 890kg Roll Drum with and without nitrogen (EMEAI)

Solstice GBA Isotainer

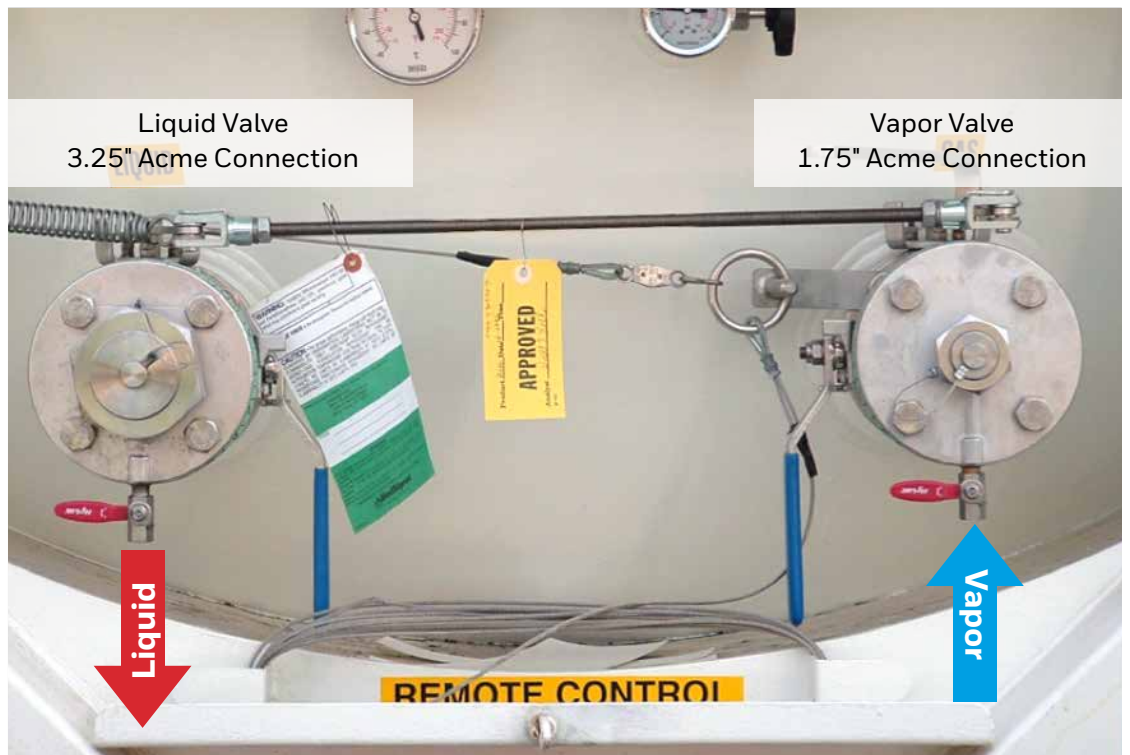

Figure 13. (Global) Note: Valve and piping configurations may vary by isotainer.

Solstice GBA 5kg Returnable Cylinder



Figure 14. (EMEAI)

Solstice GBA 50kg Returnable Cylinder



Figure 15. With and without nitrogen (EMEAI)

Solstice GBA 30lb/13.6 kg Returnable Cylinder

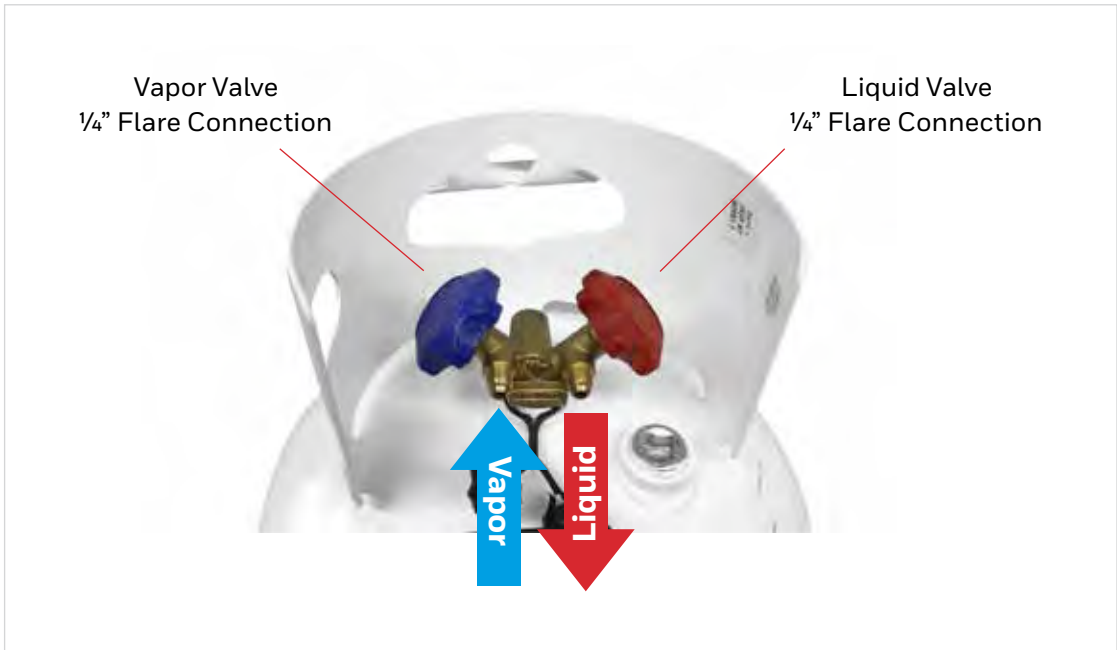

Figure 16. (Canada)

Polyol (Master Batch) Blending

Polyurethane: Polyol Blending Operations

In general, preparation of a polyurethane or polyisocyanurate polyol master batch, or polyol premix, is accomplished by the measurement and blending of the polyol (or polyol blend) with all other ingredients (surfactants, catalysts, water, and others) except blowing agent, into a suitable master batch vessel. The blowing agent is then incorporated, as a final step, into the polyol master batch to complete the fully formulated system.

CAUTION: Circulating polyol blend piping configuration should not allow the liquid to 'free-fall' through the vapor space. Free falling organic materials have the potential to build up a static electrical charge and can froth the tank.

Due to the nature of Solstice GBA, i.e., liquefied gas under pressure and low boiling point of -2.2°F (-19°C), one must take care to properly process the material in its liquid state. Proper equipment and methods must be used to safely manage this process; some examples are listed below.

Typically, closed loop blending in temperature controlled, pressure-rated equipment is necessary. One also must be cautious of the material boiling out of a polyol premix causing frothing.

Efficient and uniform blending of Solstice GBA into polyol is impacted by the bulk temperature of the polyols. Furthermore, temperature of the polyol introduces a separate complexity to the blending operation.

- Solstice GBA is a liquefied gas under pressure and will vaporize out of the polyol (into the polyol blend vessel head space) at typical ambient temperatures and especially at elevated temperatures. Cooling the polyol can help to minimize this effect.
- Polyols, in general, are relatively viscous materials, with the viscosity increasing with lower temperatures. This increase in viscosity not only presents a challenge with Solstice GBA solubility into the polyol, but increases the difficulty of pumping and stirring the polyol. At the extreme, if the polyol is very viscous, two separate layers of polyol and Solstice GBA will form in the blend vessel.

The fully formulated polyol master batch blend containing blowing agent can be accomplished by any of several methods. Some illustrative examples are:

- Master batch tank blending, in which the Solstice GBA is added directly into the polyol blend vessel. The blowing agent should be added below the liquid level of polyol in the blend vessel. This may be accomplished by either: 1) a circulation return flow below the polyol liquid level; or 2) by a dip pipe below the polyol liquid level.
 - The polyol blend vessel contains a paddle type stirring mechanism
 - The polyol blend may additionally be circulated from the bottom of the blend tank, and the circulating polyol returned below the liquid level in the polyol blend vessel, to mitigate stratification and ensure uniform mixing.
- Addition of Solstice GBA in master batch blending as described above may also include the use of a static mixer in a circulation loop, wherein the Solstice GBA is added at the static mixer.
- Separate blowing agent blending equipment wherein liquid Solstice GBA (liquefied gas) is blended into a circulating polyol stream.
- Addition of Solstice GBA via a blending system

NOTE: These are general polyol blending procedures, and it should be noted that variations on these processes may be indicated by the process configuration in the polyurethane or polyisocyanurate foaming operation in the individual manufacturing plants.

It should be noted that to assure accuracy and repeatability of the fully formulated polyol system, all ingredients should be accurately measured by utilization of a scale or load cells on the master batch blend vessel; or alternatively, the ingredients are metered by accurate flow measurement devices.

Honeywell recommends using a closed, pressure-rated tank for polyol blending. The tank should preferably be designed for use with neat Solstice GBA at elevated temperature (130°F/54°C plus 10% safety factor). At a minimum, it must be designed to accommodate the vapor pressure of the polyol blend.

Alternatively, Solstice GBA may also be added as a third stream at or near the foam head either directly or to the polyol or isocyanate streams before the head via an inline mixer.

Solstice GBA Polyol and PMDI Miscibility

Formulation development and blowing agent blending into the polyol master batch and/or isocyanate is an important part of the production of polyurethane and polyisocyanurate foams. One of the main factors one should consider when developing formulations or designing polyol blending systems is the miscibility of the blowing agent in the polyol premix. The miscibility of a sampling of polyols and PMDI materials are represented in the table below. Consult Honeywell or the material suppliers for additional information on the miscibility of Solstice GBA in raw materials.

Miscibility Test Procedure:

A mixture containing various compositions of Solstice GBA and polyol or isocyanate is prepared in a glass pressure reaction vessel, also commonly known as a Fisher-Porter tube. The mixture is thoroughly mixed at an elevated temperature (86°F / 30°C) and then placed in a constant temperature bath (75°F / 24°C) for 24 hours. The height of the polyol or isocyanate and of Solstice GBA blowing agent is measured and the miscibility is noted by visual observation (see Table 8).

If the mixture is turbid, cloudy, or not uniform, the appearance is noted and it is allowed to equilibrate until a constant separation is measured.

Miscibility of Solstice GBA in Select Polyols and PMDI

Material/Concentration		5%	10%	15%	20%
Polyols					
	Voranol ¹ RH360	Miscible	Miscible	Miscible	Miscible
	Voranol 350x	Immiscible	Immiscible	Immiscible	Immiscible
	Voranol 470x	Miscible	Miscible	Miscible	Miscible
	Pluracol ² 824	Immiscible	Immiscible	Immiscible	Immiscible
	Terate ³ 2541	Immiscible	Immiscible	Immiscible	Immiscible
PMDI					
	Lupranate ⁴ M20S	Miscible	Miscible	Immiscible	Immiscible
	Lupranate M70R	Immiscible	Immiscible	Immiscible	Immiscible

Suppliers:

1. Voranol is a registered trademark of Dow Chemical.
2. Pluracol is a registered trademark of BASF.
3. Terate is a registered trademark of Invista.
4. Lupranate is a registered trademark of BASF.

Table 8. Miscibility at 75°F (24°C) of Selected Polyols and PMDI

Extruded Thermoplastic Foams

With an extruded thermoplastic foaming process, such as extruded polystyrene (XPS) and others, the blowing agent is added directly into the polymer melt in the extruder. Liquid (liquefied gas) blowing agent is introduced, usually via a pump through a metering device to the extruder without significant regard to temperature, as the polymer melt is at elevated temperatures.

Solstice GBA will be handled as a neat material from the storage vessel, through the feed pumps, directly to the extrusion operation. Therefore, all materials of construction through this part of the process should be compatible with neat Solstice GBA.

As with most other blowing agents, the extrusion operation will likely include the use of one or more co-blowing agents. Judicious and appropriate choice of co-blowing agent(s) will be determined by the foam manufacturer in accordance with finished foam requirements, either thermal or mechanical, and the configuration and capability of the individual extrusion operation. The addition of co-blowing agent(s) to the extruder will be a separate addition directly to the extruder, and may or may not be at the same location in the extruder as the Solstice GBA.

Drawings

A variety of drawings and schematics have been included in this manual to illustrate and describe the ideas and processes written in this document.

Drawing 1 is the layout and general specifications for a Solstice GBA bulk storage vessel. As is described in this document, standard fluorocarbon storage tanks come in sizes ranging from 6,565 gallons or 24,851 liters (tank truck size) to 30,000 gallons or 113,562 liters (rail car size). This drawing is the pressure vessel design (at the time of this manual's publication) in which the delivery vessel unloading lines (liquid and vapor) are located on the bottom of the tank. Older tanks currently in service may have both unloading lines on the top of the bulk storage vessel.

Drawing 2 gives additional detail for the Solstice GBA bulk storage system. This drawing shows the schematic for the pumping station, as well as additional detail on the bulk storage vessel. This drawing reflects a standard, skid-mounted bulk storage system.

Drawing 3 shows the process schematic and illustrates a Solstice GBA bulk delivery trailer connected to the Solstice GBA bulk storage tank. As described in this document, Solstice GBA is available in cylinders, in addition to bulk shipments.

Drawing 4 illustrates the two types of one-ton cylinders that are utilized in fluorocarbon service. Note that there are differences in concave and convex heads on the cylinder. Also observe the configuration of the liquid and vapor valves and internal legs. This illustrates the importance of proper cylinder orientation to effectively transfer Solstice GBA from the ton cylinder to the process.

Drawing 5 is a schematic of an unloading station for one-ton cylinder operation. Note the orientation of the liquid and vapor valves on the cylinder on the vertical axis.

Drawing 6 illustrates a process flow diagram for Solstice GBA from the liquid and vapor lines that connect to the bulk tank, through to the foam head. This schematic is typical of many polyurethane operations; however, individual operations may have some differences in the process equipment or configuration.

In Drawing 6, the dashed line toward the bottom of the page separates the typical operations of a systems house, from an operation such as may be found in a refrigerator manufacturing facility or a boardstock manufacturing facility. A polyurethane systems manufacturer would stop with the fully formulated polyol and proceed to packaging and shipping for their ultimate end-use customer. In a refrigerator or boardstock operation, the blended polyol system would proceed forward to additional holding tanks or day tanks, and subsequently to the foam head.

There is a section in this document describing Solstice GBA packages (see pg. 19).

Drawings 7 and 8 illustrate a typical piping (tubing) configuration for Solstice GBA removal and use from a 100lb cylinder and a one half-ton cylinder.

Bulk Storage Vessel Specifications

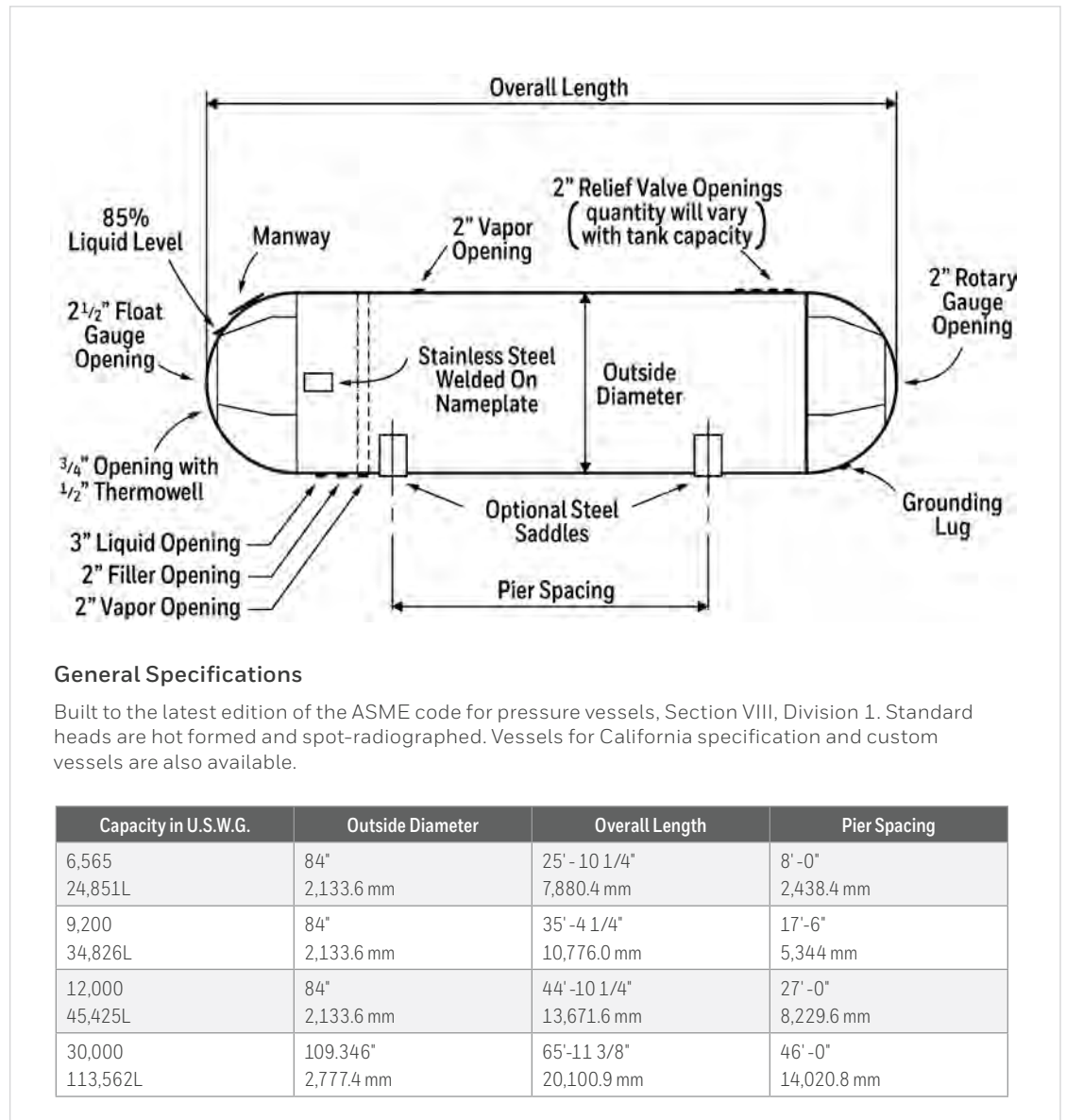

Drawing 1

Bulk Storage Additional Details

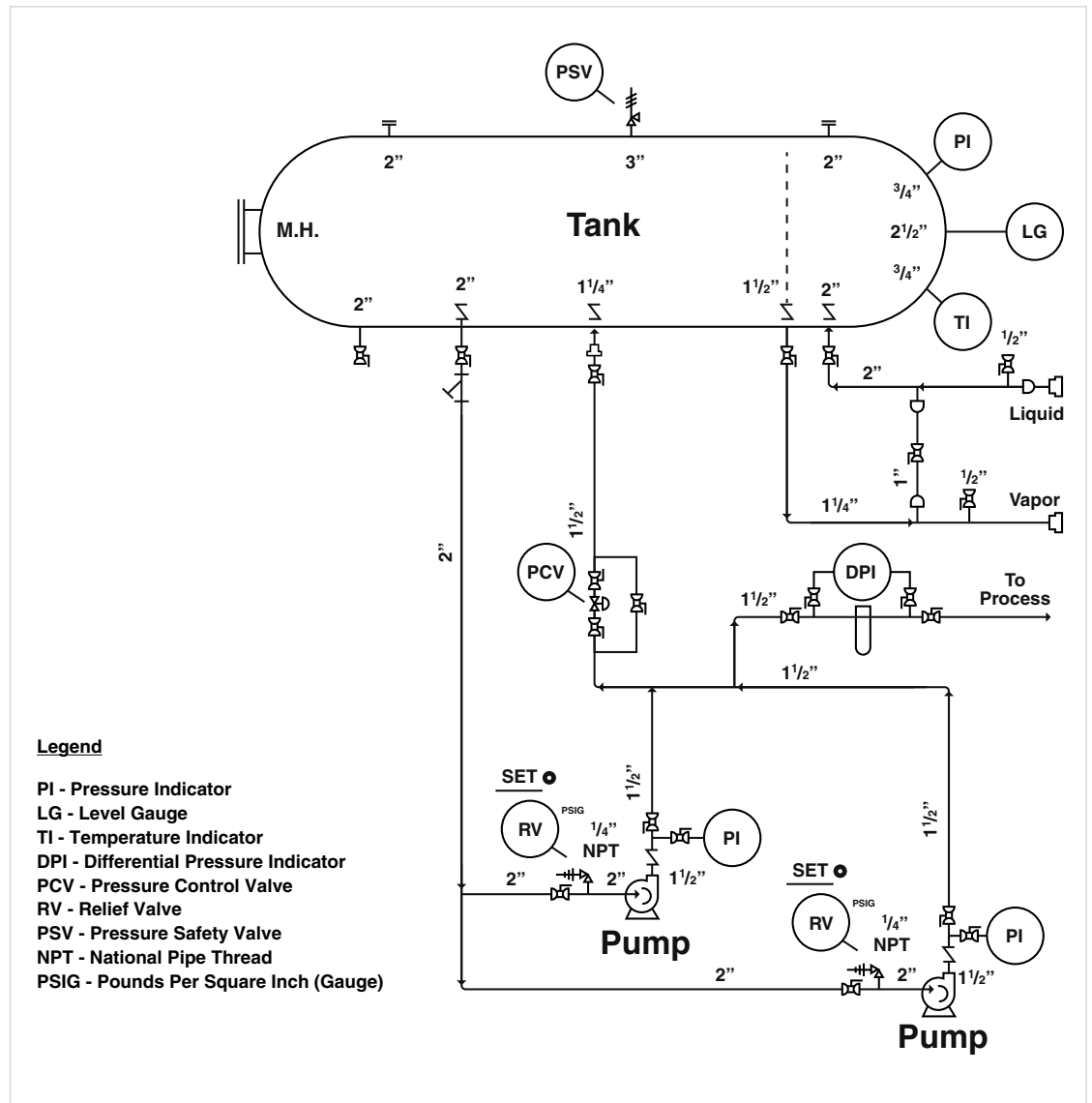

Drawing 2

Bulk Transport Trailer to Tank Connection

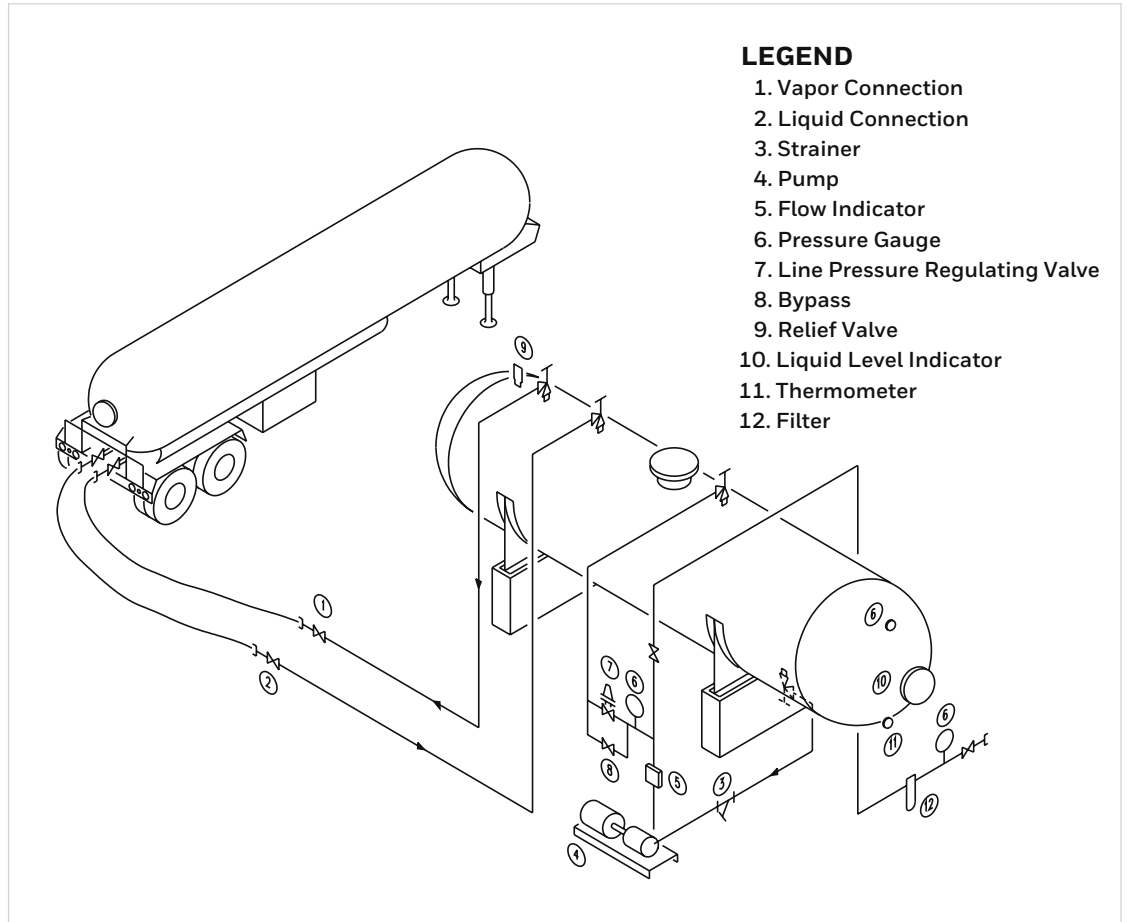

Drawing 3

One-Ton Cylinders

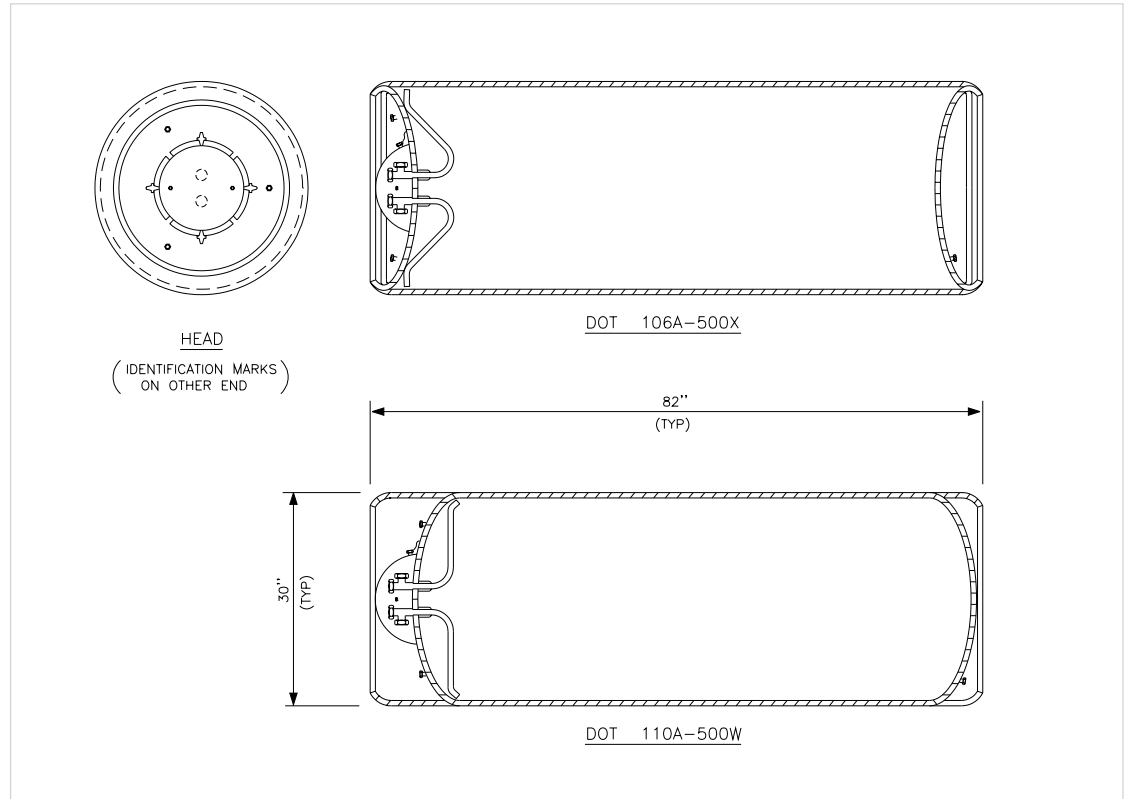

Drawing 4

One-Ton Cylinder Pumping Configuration

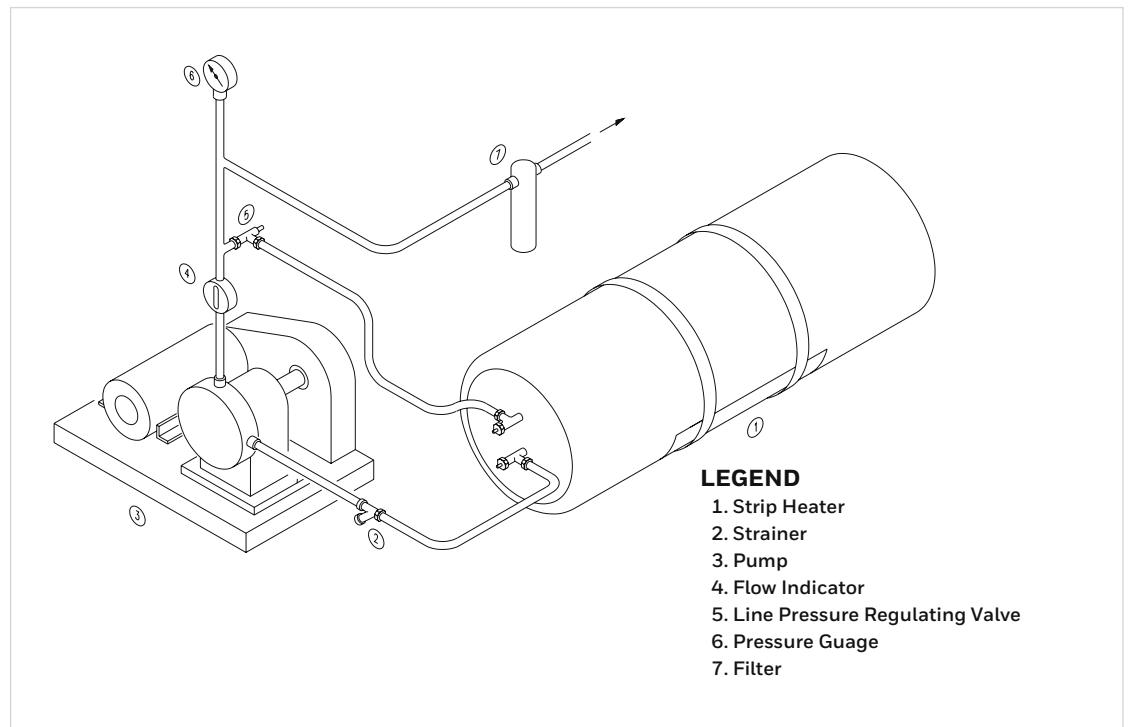

Drawing 5

Typical Bulk Storage and PUR/PIR Master Batch Configuration

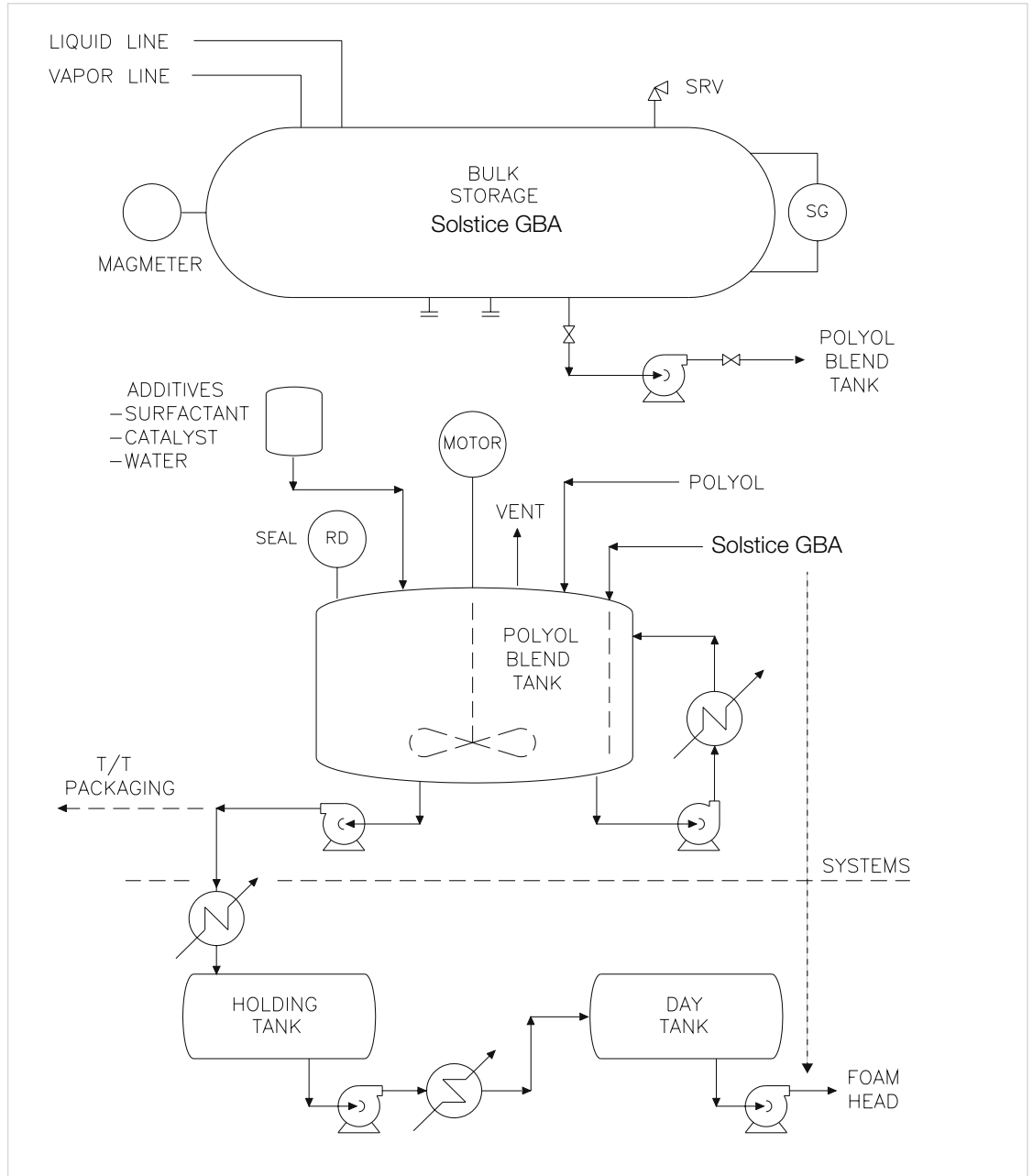

Drawing 6

Package Piping Configuration: 100lb Cylinder

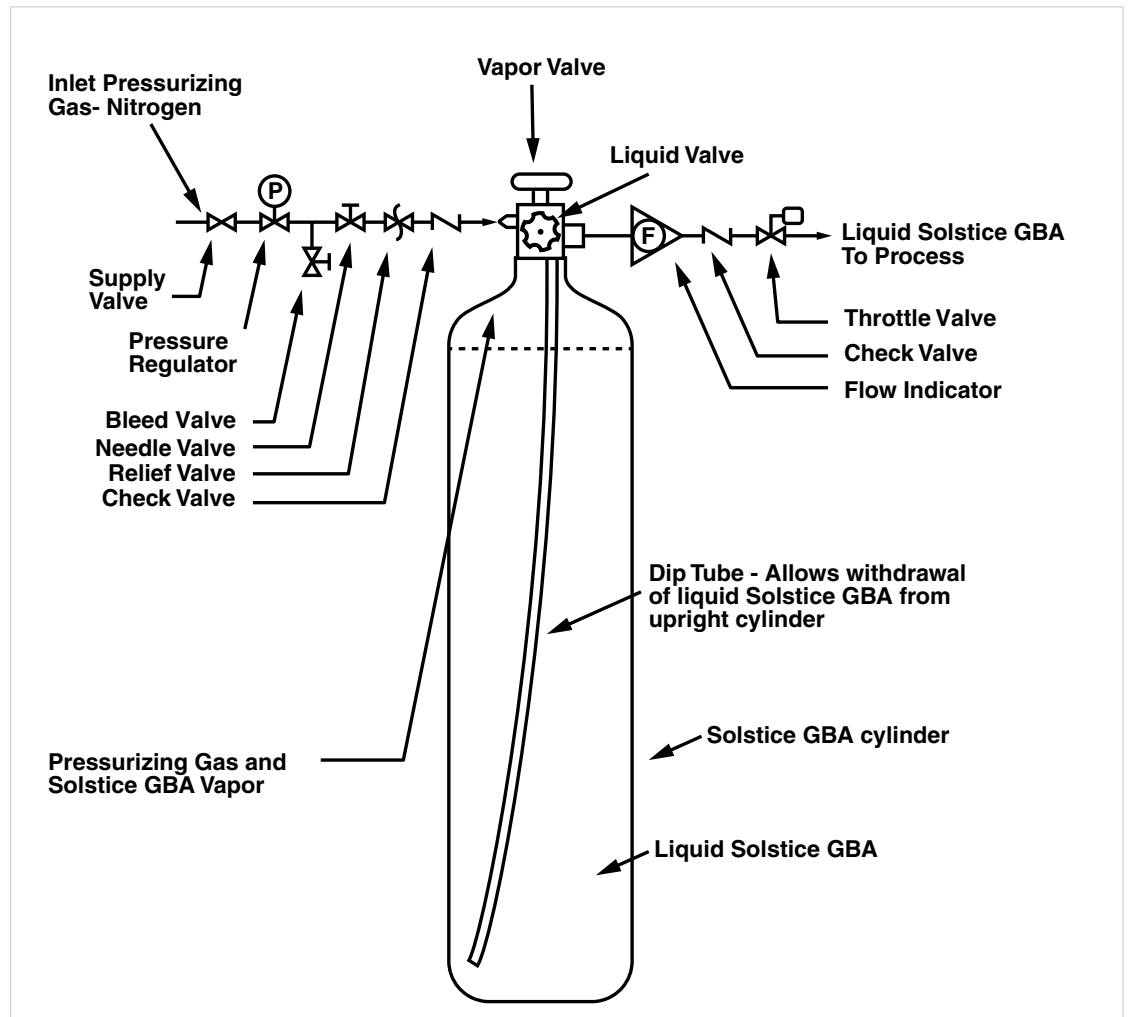

Drawing 7. MAXIMUM RECOMMENDED WORKING PRESSURE: 260 PSIG

Package Piping Configuration: One Half-Ton Cylinder

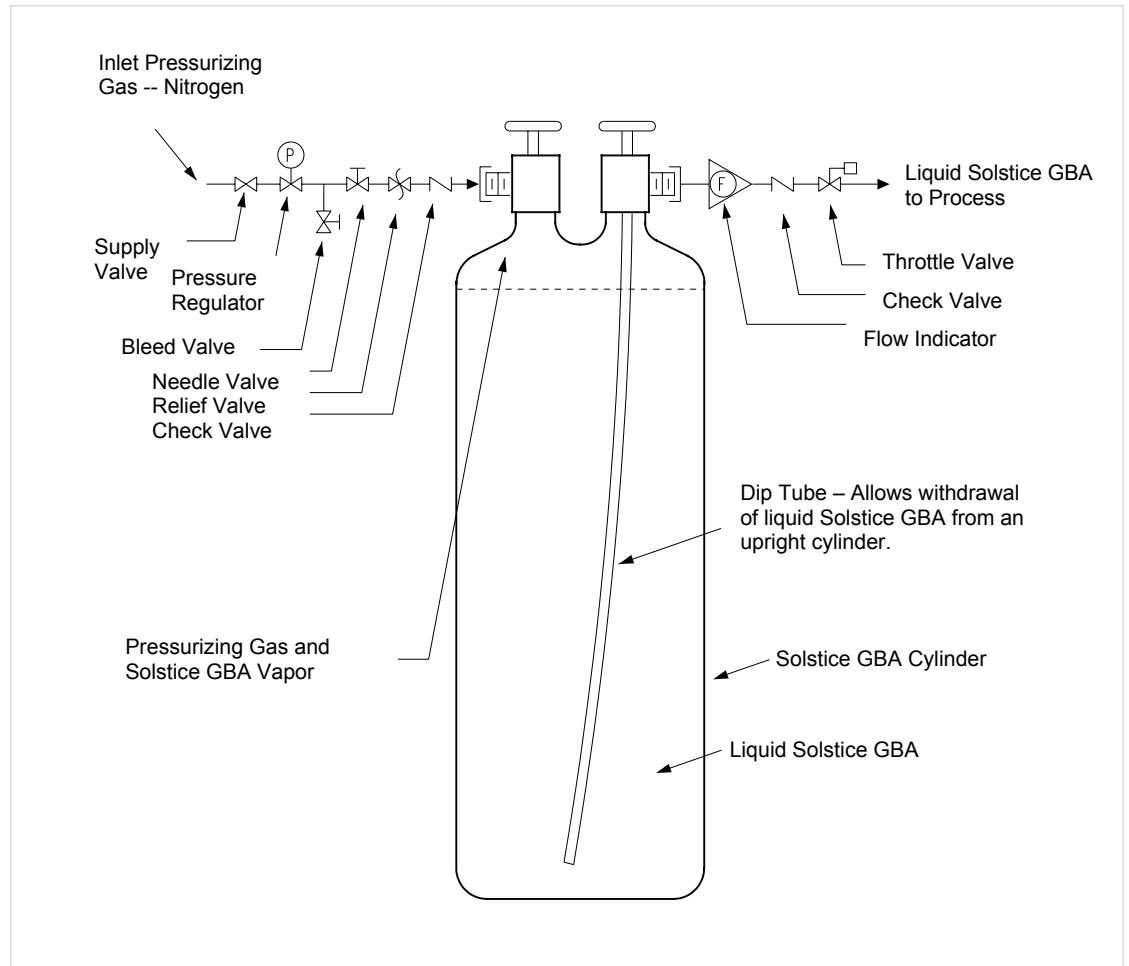

Drawing 8. MAXIMUM RECOMMENDED WORKING PRESSURE: 260 PSIG

Appendices

Vapor Pressure of Blowing Agent* – English Units

	HCFC-22	HFC-134a	HCFC-142b	Solstice GBA
Temperature (°F)	Pressure (psia)	Pressure (psia)	Pressure (psia)	Pressure (psia)
-40	15.263	7.4272	3.4549	5.3297
-35	17.336	8.5756	4.0081	6.1699
-30	19.624	9.8624	4.6311	7.1135
-25	22.142	11.299	5.33	8.1695
-20	24.906	12.898	6.1116	9.3473
-15	27.929	14.671	6.9826	10.657
-10	31.23	16.632	7.9501	12.107
-5	34.824	18.794	9.0217	13.71
0	38.728	21.171	10.205	15.476
5	42.96	23.777	11.508	17.416
10	47.536	26.628	12.938	19.542
15	52.475	29.739	14.506	21.865
20	57.795	33.124	16.218	24.398
25	63.514	36.8	18.084	27.153
30	69.651	40.784	20.113	30.143
35	76.225	45.092	22.315	33.382
40	83.255	49.741	24.699	36.882
45	90.761	54.749	27.276	40.658
50	98.763	60.134	30.054	44.723
55	107.28	65.913	33.044	49.093
60	116.33	72.105	36.258	53.781
65	125.94	78.729	39.704	58.802
70	136.13	85.805	43.394	64.172
75	146.92	93.351	47.339	69.905
80	158.33	101.39	51.55	76.019
85	170.38	109.93	56.038	82.528
90	183.09	119.01	60.814	89.45
95	196.5	128.65	65.89	96.8
100	210.61	138.85	71.278	104.6
105	225.46	149.65	76.988	112.85
110	241.06	161.07	83.034	121.59
115	257.45	173.14	89.428	130.83
120	274.65	185.86	96.181	140.58
125	292.69	199.28	103.31	150.87
130	311.58	213.41	110.82	161.72
135	331.37	228.28	118.72	173.14
140	352.08	243.92	127.04	185.15
145	373.74	260.36	135.78	197.78
150	396.38	277.61	144.96	211.05
155	420.04	295.73	154.59	224.97
160	444.75	314.73	164.68	239.58

Table 9

* These are but some of a mosaic of properties that must be evaluated in assessing candidate blowing agents.

Vapor Pressure of Blowing Agent* – SI Units

	HCFC-22	HFC-134a	HCFC-142b	Solstice GBA
Temperature (°C)	Pressure (kPa)	Pressure (kPa)	Pressure (kPa)	Pressure (kPa)
-40	105.23	51.209	23.821	36.747
-35	132.03	66.144	31.03	47.685
-30	163.89	84.378	39.911	61.094
-25	201.43	106.4	50.729	77.355
-20	245.31	132.73	63.771	96.872
-15	296.2	163.94	79.343	120.08
-10	354.79	200.6	97.773	147.44
-5	421.8	243.34	119.41	179.42
0	497.99	292.8	144.6	216.55
5	584.11	349.66	173.74	259.34
10	680.95	414.61	207.21	308.36
15	789.31	488.37	245.43	364.16
20	910.02	571.71	288.81	427.34
25	1043.9	665.38	337.78	498.52
30	1191.9	770.2	392.79	578.33
35	1354.8	886.98	454.3	667.41
40	1533.6	1016.6	522.76	766.45
45	1729.2	1159.9	598.66	876.15
50	1942.7	1317.9	682.48	997.22
55	2175.1	1491.5	774.73	1130.4
60	2427.5	1681.8	875.91	1276.6
65	2701.2	1889.8	986.55	1436.5
70	2997.4	2116.8	1107.2	1611

Table 10

* These are but some of a mosaic of properties that must be evaluated in assessing candidate blowing agents.

Solstice GBA Vapor Pressure Comparison (English Units)

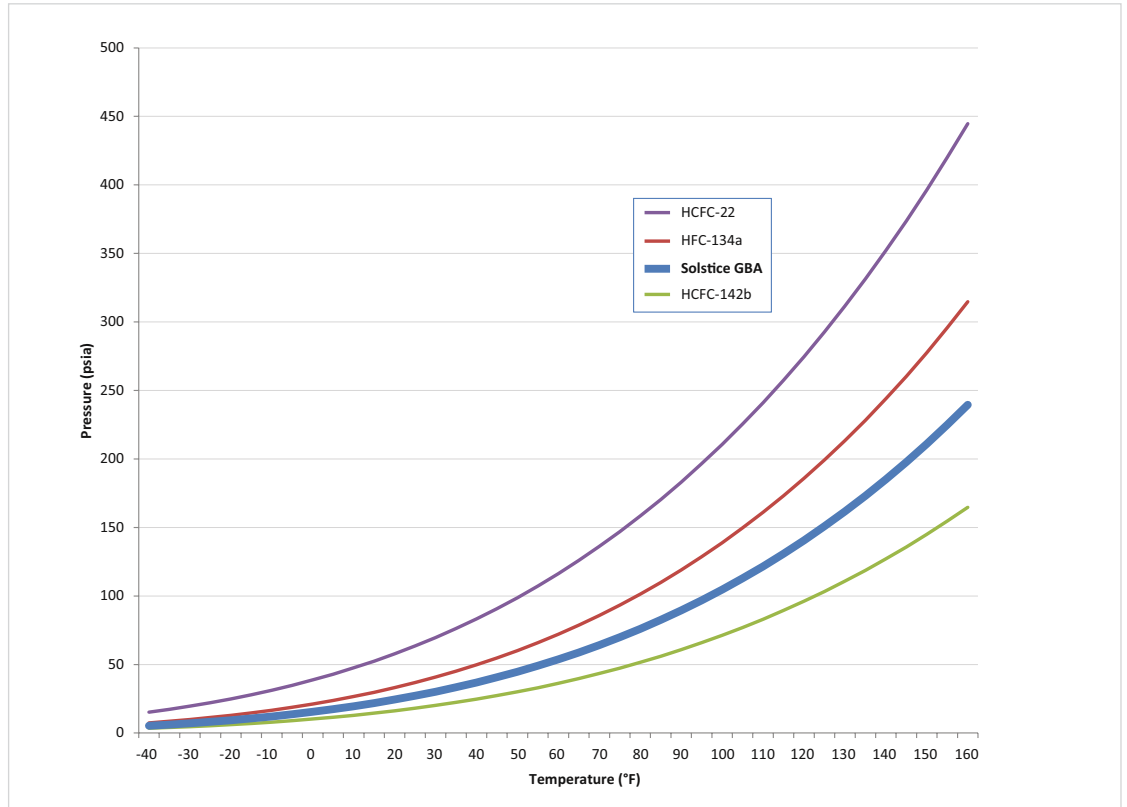

Figure 17

Solstice GBA Vapor Pressure Comparison (SI Units)

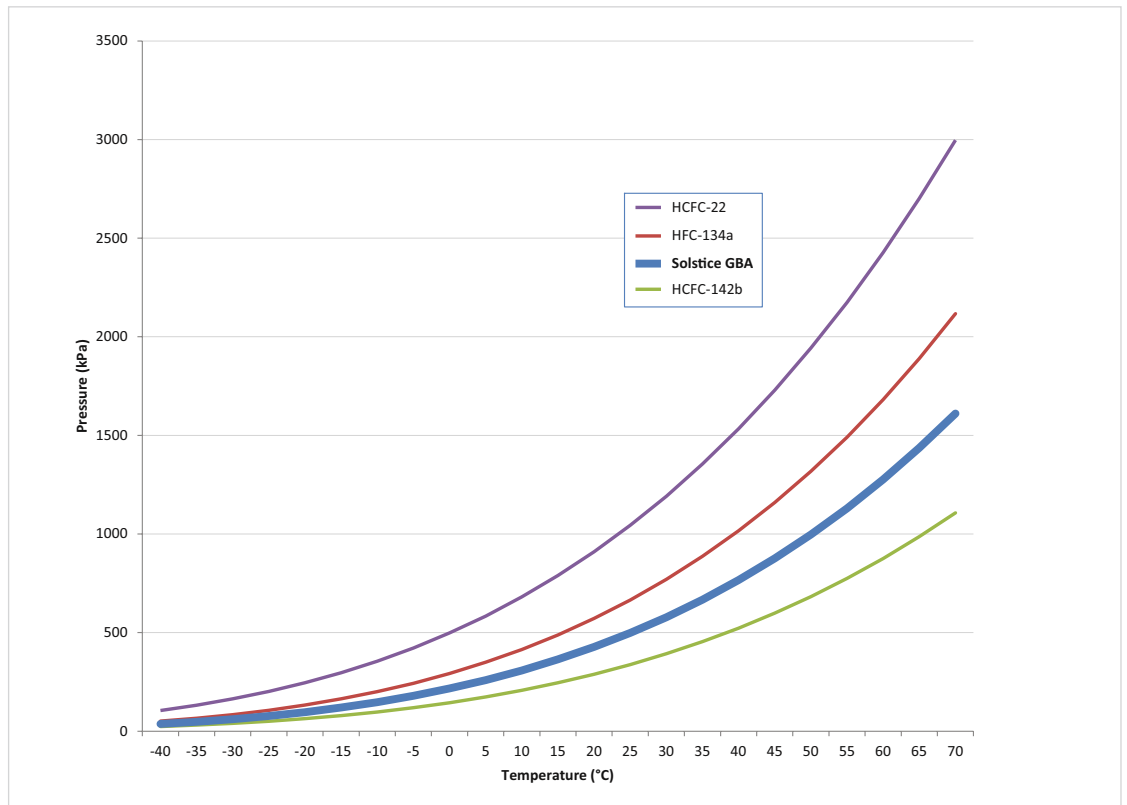

Figure 18

Reference Notes

- 2014 UNEP Rigid and Flexible Foams Technical Options report, Table 1, unless otherwise noted
- Flammability measurements: ASTM D-3828 / ASTM D-1310/ASTM E-681/EU Test Method A11, unless otherwise specified
- Climate Change 2013: The Physical Science Basis: Fifth Assessment Report of the Intergovernmental Panel on Climate Change (IPCC), 2013
- Acetal used in test: "Delrin": Registered Trademark of DuPont
- Polyetherimide used in test: "Ultem": Registered Trademark of the General Electric Company
- PVDF used in test: "Kynar": Registered Trademark of the Atofina Company
- PTFE used in test: "Teflon": Registered Trademark of The Chemours Company
- Fluoroelastomer used in test: "Viton B": Registered Trademark of The Chemours Company
- Nitrile Rubber used in test: "Buna N"
- TPU used in test: "Texin": Registered Trademark of Covestro
- Perfluoroelastomer used in test: "Kalrez 6375": Registered Trademark of DuPont
- NIST Reference Fluid Properties (REFPROP) version 9.1
- MONEL™: Registered Trademark of the Special Metals Corporation
- Low GWP Refrigerant Options For Unitary AC & Heat Pumps – Mark Spatz, ASHRAE Jan 2011
- Phillips Petroleum Company "Nine Light Hydrocarbons" 1942B-96 A 01 1996
- [http://www2.mathesongas.com/pdfs/products/Lower-\(LEL\)-&-Upper-\(UEL\)-Explosive-Limits-.pdf](http://www2.mathesongas.com/pdfs/products/Lower-(LEL)-&-Upper-(UEL)-Explosive-Limits-.pdf)
- <http://www.crohmiq.com/mie-fibc-minimum-ignition-energy-antistatic-big-bags.html>
- http://www.protocolodemontreal.org.br/eficiente/repositorio/Ciclo%20de%20Palestras/ciclo_de_palestras/853.pdf
- http://phmsa.dot.gov/staticfiles/PHMSA/DownloadableFiles/Files/PHH50_0078_0706_UN_Cylinders.pdf
- https://trainex.org/osc2012/uploads/516/40_Sec%205%20-%20Cylinder%20Identification%202.pdf
- <https://www.honeywell-refrigerants.com/americas/?document=genetron-134a-technical-brochure-properties-uses-storage-and-handling&download=1>

For more information

To learn more about the benefits of Solstice® Gas Blowing Agent, visit sustainability.honeywell.com

Honeywell Advanced Materials

115 Tabor Road
Morris Plains, NJ 07950
www.honeywell.com



Although Honeywell International Inc. believes that the information contained herein is accurate and reliable, it is presented without guarantee or responsibility of any kind and does not constitute any representation or warranty of Honeywell International Inc., either expressed or implied. A number of factors may affect the performance of any products used in conjunction with user's materials, such as other raw materials, application, formulation, environmental factors and manufacturing conditions among others, all of which must be taken into account by the user in producing or using the products. The user should not assume that all necessary data for the proper evaluation of these products are contained herein. Information provided herein does not relieve the user from the responsibility of carrying out its own tests and experiments, and the user assumes all risks and liabilities (including, but not limited to, risks relating to results, patent infringement, regulatory compliance and health, safety and environment) related to the use of the products and/or information contained herein.

Solstice is a registered trademark of Honeywell International Inc.
1210 FP BA | v18 | 02/22
© 2022 Honeywell International Inc.

**THE
FUTURE
IS WHAT
WE
MAKE IT**

Honeywell